

PRODUCED BY THE OPERATIONS DIRECTORATE OF ENERGY NETWORKS ASSOCIATION

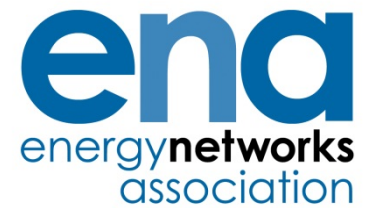

Engineering Recommendation EREC S34

Issue 2, November 2018

A guide for assessing the rise of earth potential
at electrical installations

PUBLISHING AND COPYRIGHT INFORMATION

© 2018 *Energy Networks Association*

All rights reserved. No part of this publication may be reproduced, stored in a retrieval system or transmitted in any form or by any means, electronic, mechanical, photocopying, recording or otherwise, without the prior written consent of Energy Networks Association. Specific enquiries concerning this document should be addressed to:

**Operations Directorate
Energy Networks Association
6th Floor, Dean Bradley House
52 Horseferry Rd
London
SW1P 2AF**

This document has been prepared for use by members of the Energy Networks Association to take account of the conditions which apply to them. Advice should be taken from an appropriately qualified engineer on the suitability of this document for any other purpose.

First published 1986.

Amendments since publication

Issue	Date	Amendment
1	May 1986	Amendment 1 – Minor changes to figure 17
1	1988	Amendment 2 – Minor changes to formulae on pages 25 and 27
2	8 November 2018	Major revision and re-write. Alignment with latest revisions of BS EN 50522, BS 7430 and ENA TS 41-24. New formulae introduced.

Contents

Introduction	8
1 Scope	8
2 Normative references	8
3 Terms and definitions	8
3.1 Symbols used.....	8
3.2 Formulae used for calculating earth installation resistance for earthing studies.....	8
3.3 Description of system response during earth fault conditions	9
4 Earth fault current studies.....	11
4.1 Earth fault current.....	11
4.2 Fault current analysis for multiple earthed systems	11
4.3 Induced currents in parallel conductors	12
4.3.1 Simple circuit representation for initial estimates.....	12
4.3.2 More realistic circuit representation to improve the accuracy of calculations.....	12
4.3.3 Amending calculations to account for increased ground return current in single-core circuits that are not in trefoil touching arrangement.....	13
5 EPR impact calculations	14
5.1 Calculation of touch potentials.....	14
5.2 Calculation of step potentials.....	14
5.3 Surface potential contours	14
5.4 Transfer potential to LV systems where the HV and LV earthing are separate	14
5.4.1 Background	14
5.4.2 Basic theory.....	15
5.5 Methods of optimising the design	16
5.5.1 More accurate evaluation of fault current.....	16
5.5.2 Reducing the overall earth impedance.....	17
5.5.3 Reducing the touch potential within the installation.....	17
5.6 Risk assessment methodology	17
6 Case study examples	18
6.1 Case study 1: 33 kV substation supplied via overhead line circuit	18
6.1.1 Resistance calculations	19
6.1.2 Calculation of fault current and earth potential rise	24
6.1.3 Calculation of touch potentials	24
6.1.4 External touch potential at the edge of the electrode	25
6.1.5 Touch potential on fence.....	26
6.1.6 Internal touch potentials.....	26
6.1.7 Calculation of external voltage impact contours	26
6.2 Case study 2: 33 kV substation supplied via cable circuit.....	27
6.2.1 Resistance calculations	27
6.2.2 Calculation of fault current and EPR	28
6.2.3 C-factor method.....	28

6.2.4	Matrix method.....	29
6.2.5	Results	30
6.3	Case study 3: 33 kV substation supplied via mixed overhead line/cable circuit.....	30
6.3.1	Resistance calculations	31
6.3.2	Calculation of fault current and earth potential rise	31
6.4	Case study 4: Multiple neutrals.....	33
6.4.1	Introduction.....	33
6.4.2	Case study data.....	35
6.4.3	Treatment of neutral current	35
6.4.4	Fault current distribution	36
6.4.5	Earth potential rise (EPR)	37
6.5	Case study 5: 11 kV substation and LV earthing interface	37
6.5.1	Design option 1.....	37
6.5.2	C-factor method.....	38
6.5.3	Matrix method.....	39
6.5.4	Results	39
6.5.5	Surface current density.....	39
6.5.6	Design option 2.....	40
6.5.7	C-factor method.....	41
6.5.8	Matrix method.....	41
6.5.9	Results	42
APPENDICES.....		43
Appendix A	Symbols used within formulae or figures.....	44
Appendix B	Formulae	47
Appendix C	Earthing design methodology	57
Appendix D	Formulae for determination of ground return current for earth faults on metal sheathed cables.....	58
Appendix E	Ground return current for earth faults on steel tower supported circuits with an aerial earth wire.....	68
Appendix F	Typical values of earth resistance of long horizontal electrode.....	69
Appendix G	Chain impedance of standard 132kV earthed tower lines	70
Appendix H	The effect on ground return current for changes in geometry.....	71
Appendix I	Transfer potential to distributed LV systems	76
Bibliography.....		80

Figures

Figure 1 — Earth fault at an installation which has an earthed tower line supply.....	10
Figure 2 — Equivalent circuit for analysis.....	11
Figure 3 — Surface potential near a simple HV and LV electrode arrangement.....	15
Figure 4 — Equivalent circuit for combined LV electrodes A and B.....	16
Figure 5 — Case study 1: Supply arrangement.....	18
Figure 6 — Substation B basic earth grid.....	19
Figure 7 — Substation B basic earth grid and rods.....	20
Figure 8 — Substation B earth grid with rods and re-bar.....	22
Figure 9 — Case study 2: Supply arrangement.....	27
Figure 10 — Case study 3: Supply arrangement.....	30
Figure 11 — Case study 3: Equivalent circuit.....	31
Figure 12 — Case study 4: Supply arrangement.....	34
Figure 13 — Case study 5: Option 1.....	37
Figure 14 — Case study 5: Option 2.....	40
Figure B.1 — factor k for formula R5.....	48
Figure D.1 — Cable circuit, local source, fault at cable end.....	58
Figure D.2 — Cable-line circuit, local source, remote fault.....	59
Figure D.3 — Line-cable circuit, remote source, fault at cable end.....	60
Figure D.4 — Line-cable-line circuit, remote source, remote fault.....	61
Figure F.1 — Typical values of earth resistance of long horizontal electrode.....	69
Figure H.1 — Cross-sectional view for cable 3.....	72
Figure H.2 — Circuit used for analysis purposes.....	72
Figure H.3 — Ground return current (I_E) as a percentage of (I_F) against circuit length for different 132 kV cable installation arrangements.....	73
Figure H.4 — Ground return current (I_E) as a percentage of (I_F) against circuit length for different 11 kV cable installation arrangements.....	74
Figure I.1 — Example 1: Two electrodes of equal resistance.....	76
Figure I.2 — Example 2: Two electrodes of unequal resistance.....	77
Figure I.3 — Example of pole-mounted 11 kV substation arrangement and LV supply to a dwelling.....	79

Tables

Table 1 — Fault clearance time and permissible touch potentials	19
Table 2 — EPR for different grid arrangements.....	24
Table 3 — Fault clearance time and permissible touch potentials	27
Table 4 — Input data and results	28
Table 5 — Complex representation of cable self and mutual impedances.....	29
Table 6 — Resultant fault current distribution and EPR (matrix method).....	30
Table 7 — Input data and results for final part of circuit.....	32
Table 8 — Input data and results for initial part of circuit.....	33
Table 9 — Case study 4: Short-circuit data.....	35
Table 10 — Sum of contributions to earth fault current.....	35
Table 11 — Information for fault current distribution calculations	36
Table 12 — Calculated ground return current	36
Table 13 —Option 1 input data and results	39
Table 14 — Resultant fault current distribution and EPR (matrix method).....	39
Table 15 — Option 2 input data and results	41
Table 16 — Resultant fault current distribution and EPR (matrix method).....	41
Table B.1 - Approximate lengths for a single horizontal earth wire, tape or PILCSWA cable beyond which no further significant reduction in resistance can be obtained	49
Table D.1 — Self and mutual impedances for a sample of three-core cables.....	64
Table D.2 — Self and mutual impedances for a sample of single-core (triplex) cables.....	65
Table E.1 — Ground return current as % of earth fault current for tower lines.....	68
Table G.1 — Chain impedance for 132 kV tower lines	70
Table H.1 — Technical details of cables modelled	71
Table H.2 — Geometric placement of cables	71

Foreword

This Engineering Recommendation (EREC) is published by the Energy Networks Association (ENA) and comes into effect from 8 November, 2018. It has been prepared under the authority of the ENA Engineering Policy and Standards Manager and has been approved for publication by the ENA Electricity Networks and Futures Group (ENFG). The approved abbreviated title of this engineering document is “EREC S34”, which replaces the previously used abbreviation “ER EREC S34”.

Introduction

This Engineering Recommendation (EREC) is the technical supplement to ENA TS 41-24 (2017), providing formulae, guidelines and examples of the calculations necessary to estimate the technical parameters associated with earth potential rise (EPR).

ENA TS 41-24 provides the overall rules, the design process, safety limit values and links with legislation and other standards.

1 Scope

This document describes the basic design calculations and methods used to analyse the performance of an earthing system and estimate the earth potential rise created, for the range of electrical installations within the electricity supply system in the United Kingdom covered by ENA TS 41-24. Modification to the calculations and methods may be necessary before they can be applied to rail, industrial and other systems.

2 Normative references

The following referenced documents, in whole or part, are indispensable for the application of this document. For dated references, only the edition cited applies. For undated references, the latest edition of the referenced document (including any amendments) applies.

ENA TS 41-24 also contains an extensive list of reference documents.

Standards publications

BS EN 50522:2011, *Earthing of power installations exceeding 1 kV a.c.*

ENA TS 41-24, *Guidelines for the Design, Installation, Testing and Maintenance of Main Earthing Systems in Substations*

BS EN 60909-3:2010, *Short-circuit currents in three-phase a.c. systems. Currents during two separate simultaneous line-to-earth short-circuits and partial short-circuit currents flowing through earth*

3 Terms and definitions

3.1 Symbols used

Symbols or a similar naming convention to BS EN 50522 have been used throughout and are listed in Appendix A. Where these differ from the symbols used in earlier versions of this document, the previous symbols are shown alongside the new ones, to assist when checking previous calculations.

3.2 Formulae used for calculating earth installation resistance for earthing studies

The most common formulae for power installations are given in Appendix B. These are generally used to calculate the resistance of an earth electrode system comprising of horizontal and/or vertical components or voltages at points of interest.

NOTE 1: Formulae in this document are those which are considered most relevant to UK network operators. They may differ from those in BS EN 50522 where the BS EN version is known to be a simplification and/or restricted in its application.

NOTE 2: Unless reference to another part of this document is given, all references to formulae, e.g. P1, R1, refer to those in Appendix B.

NOTE 3: Some formulae taken from other standards have definitions that may not be consistent with the main body of this document – e.g. formula P4 has alternative definitions for some of the parameters. These have been retained to avoid the need for alternative definitions and to allow easy cross reference with source material.

When using formulae to calculate earth resistances, caution is necessary because they do not normally account for proximity effects or the longitudinal impedance of conductors.

For first estimates, the overall earth impedance Z_E of separate electrodes with respect to reference earth is taken as the sum of their separate values in parallel. For the example shown in Figure 1 this would be:

$$Z_E = \left(\frac{1}{R_{ES}} + \frac{1}{Z_{CH1}} + \frac{1}{Z_{CH2}} + \dots \right)^{-1}$$

In reality, Z_E will be higher if the separate electrodes are close enough that their earthing resistance zones overlap (proximity effect). Proximity effects can be accounted for in most advanced software packages. When relying on standard formulae, the following techniques can help to account for proximity when calculating Z_E :

- Include any radial electrodes that are short in relation to the substation size, into the overall calculation of the earth grid resistance.
- For radial spur electrodes or cables with an electrode effect, assume the first part of its length is insulated over a distance similar to the substation equivalent diameter. Calculate the earth resistance of the remainder of the electrode/cable and add the longitudinal impedance of the insulated part in series.
- For a tower line, assume that the line starts after one span of overhead earth wire (the longitudinal impedance of this earth wire/span would be placed in series with the tower line chain impedance).

A value of soil resistivity is needed and for the formulae in Appendix B, this should be a uniform equivalent (see ENA TS 41-24, Section 7.4). For soils that are clearly of a multi-layer structure with significant resistivity variations between layers, the formulae should be used with caution and a greater level of accuracy may be provided by the use of dedicated software.

3.3 Description of system response during earth fault conditions

The arrangement shown in Figure 1 is based upon the example described in BS EN 50522 and will be explained and developed further in this document. The EPR is the product of earth electrode impedance and the current that flows through it into the soil and back to its remote source. The description below demonstrates how the fault current and associated impedances are used to arrive at the components that are relevant to the EPR.

The installation is based on a ground-mounted substation that is supplied from (or looped into) an overhead line circuit that is supported on steel towers and has an over-running earth wire. In this simplified example, currents are shown only on one of the infeed circuits for clarity, and flow in one earth wire only. It is also assumed that each tower line supports only one (three-phase) circuit.

The fault condition is a high voltage phase insulation failure to earth within the substation. It is possible to model this situation with computer software such that all of the effects are summated, calculated and results presented together. For traditional analysis in this standard, the effects are decoupled as described below.

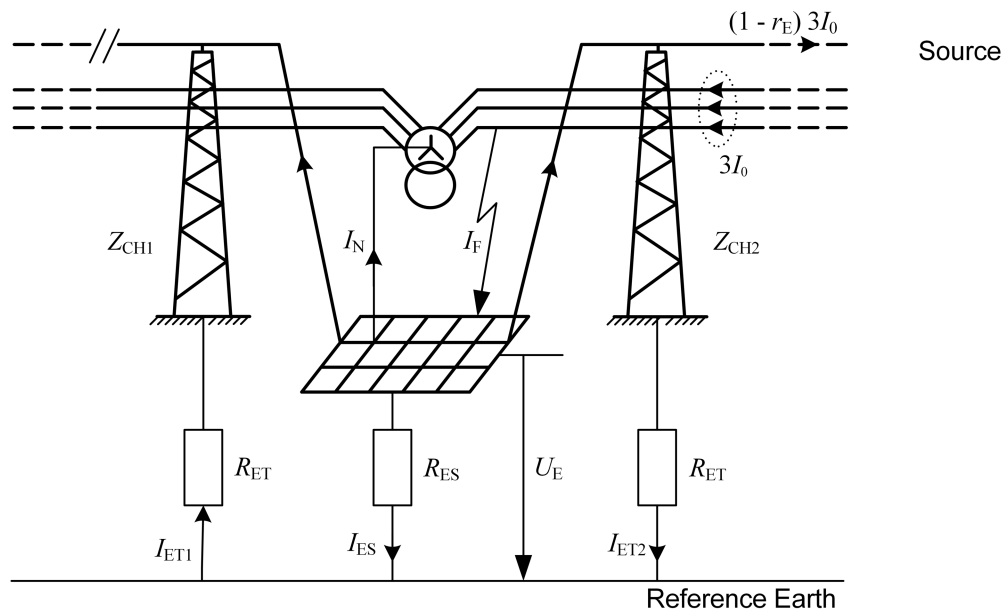

Figure 1 — Earth fault at an installation which has an earthed tower line supply

The total earth fault current at the point of fault (I_F) that will flow into the earth grid and associated components would be reduced initially by two components.

- The first component is that passing through the transformer star point earth connection (I_N) and returning to source via the unfaulted phase conductors. For systems that are normally multiply earthed, i.e. at 132 kV and above, the total current excluding the I_N component is normally calculated by summing the currents in all three phases ($3I_0$) vectorially. The process is further described in case study 4 (Section 6.4). For lower voltage distribution systems, I_N is normally zero or sufficiently low to be ignored in calculations.
- The second reduction is due to inductive coupling between the faulted phase and continuous earth conductor (see Section 4.3). This part of the current is normally pre-calculated for standard line arrangements or can be individually calculated from the support structure geometry, conductor cross section and material. A similar procedure is followed for a buried cable. Another approach is to use a reduction factor r_E based on the specific circuit geometry and material.

Once these components have been removed, the situation is shown in Figure 2. The earth current (I_E) is treated as flowing into the earth network, which in this example contains the substation earth grid (resistance R_{ES}) and two 'chain impedances' of value Z_{CH1} and Z_{CH2} . The two chain impedances are each a ladder network consisting of the individual tower footing resistance R_{ET} in series with the longitudinal impedance of each span of earth wire. They are treated as being equal if they have more than 20 similar towers in series and are in soil of similar resistivity. The overall impedance of the electrode network is Z_E and the current (I_E) flowing through it creates the earth potential rise (U_E).

The analysis of the performance of the system described follows the process shown in the design methodology flow diagram (Appendix C). The case studies in Section 6 illustrate this process for a number of examples of increasing complexity.

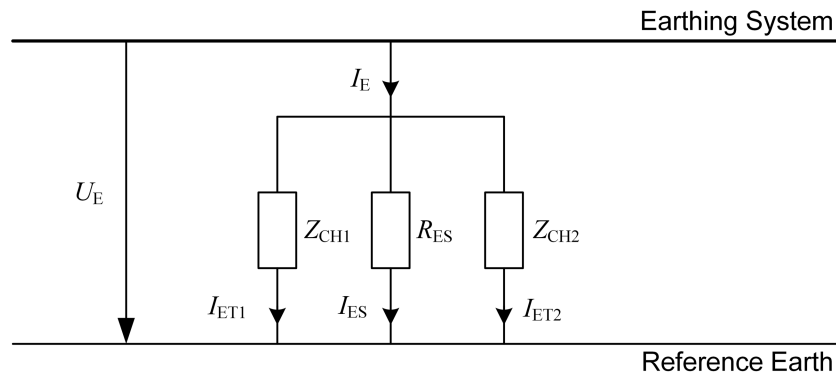

Figure 2 — Equivalent circuit for analysis

4 Earth fault current studies

This section describes how to use the fault current data (calculated using the methodology set out in BS EN 60909 and guidance from ENA TS 41-24, Section 5.4) for earth potential rise purposes.

4.1 Earth fault current

Source earth fault current values (such as the upper limit with neutral earth resistors in place) may be used for initial feasibility studies, but for design purposes, the value used should be site specific, i.e. should account for the fault resistance and longitudinal phase impedance between the source and installation.

Once the fault current is known, the clearance time for a normal protection operation (as defined in ENA TS 41-24), at this level of current should be determined and the applicable safety voltage limits obtained from ENA TS 41-24, Tables 1 and 2. This basis of a normal protection operation is used for the personnel protection assessment. Design measures should be included within installations to adequately size the earth electrode and conductor in the event of a main protection failure.

For protection and telecommunication equipment immunity studies in distribution systems, the steady state RMS fault current values are normally used. At some installations, particularly where there are significant generation in-feeds, consideration should be given to sub-transient analysis. This is especially important where vulnerable equipment (such as a telephone exchange) is installed close to a generation installation.

For calculation of the EPR, it is the ground return component of the fault current (I_E) that is of concern. On some transmission systems, this can be greater for a phase-phase-earth fault (compared to a straightforward phase-earth fault) and where applicable, this value should be used for the EPR calculation.

4.2 Fault current analysis for multiple earthed systems

The methodology followed in this document assumes that the earth fault current at the substation (possibly at a defined point in the substation) has been separately calculated using power system analysis tools, symmetrical components or equivalent methods. Depending upon the complexity of the study, the data required may be a single current magnitude or the three phase currents in all supply circuits in vector format.

4.3 Induced currents in parallel conductors

The alternating current that flows in a conductor (normally a phase conductor) will create a longitudinal emf in conductors that lie in parallel with it. Typical parallel conductors are: cable metal screens (lead sheath, steel armour or copper strands), earth wires laid with the circuit, metal pipes, traction rails or the earth wires installed on overhead lines. This emf will increase from the point of its earth connection as a function of the length of the parallelism and other factors (such as the separation distance). If the remote end of the parallel conductor is also connected to earth, then a current will circulate through it, in the opposite general direction to the inducing current.

The current that flows (returns) via the cable sheath or earth wire during fault conditions can be large and it has the effect of reducing the amount of current flowing into the ground via the electrode system, resulting in a reduced EPR on it.

The following sections provide methods to account for these return currents.

4.3.1 Simple circuit representation for initial estimates

For an overhead line with a single earth wire, or a single cable core and its earth sheath, the formulae below approximate the ground return current (I_E). The main assumption is that the circuit is long enough such that the combined value of the earthing resistances at each end of the line are small compared with z_s (earth wire impedance), or for cable, small compared with r_c (cable sheath resistance).

For an overhead line (refer to Figure 1):

$$I_E = k(I_F - I_N) \quad \text{where } k = \left(1 - \frac{z_{mp,s}}{z_s}\right)$$

where $z_{mp,s}$ is the mutual impedance between the line conductors and earth wire.

NOTE: All terms are vector quantities

Appendix E gives calculated values of I_E presented as a percentage of overall earth-fault current I_F , and phase angle with respect to I_F for a range of the most commonly used overhead line constructions at 132 kV, 275 kV and 400 kV.

For a single-core cable:

$$I_E = k(I_F - I_N) \quad \text{where } k = \left(\frac{r_c}{z_c}\right)$$

NOTE: The formulae are not sufficiently accurate for circuits less than 1 km in length. The results are also sensitive to low values of terminal (electrode) earth resistance. In these cases, the more detailed approach presented in Section 4.3.2 will be required.

4.3.2 More realistic circuit representation to improve the accuracy of calculations

More complete formulae are given in Appendix D. They require a number of circuit factors and cable-specific C-factors to provide sufficiently accurate results. C-factors have been included in Tables D.1 and D.2 for a representative sample of cables.

The case studies have been selected to show how to use the formulae and calculations for a range of different scenarios. The calculations generally provide results that are conservative, because parallel circuit earth wires or cables are not included in the circuit factors. The parallel earth wires or cables can be included in the circuit factors to provide more accurate results.

Where single-core cables are used for three-phase circuits, the calculations are based upon them being installed in touching trefoil formation, earthed at each end. Where the cables are not in this arrangement, the results may be optimistic and correction factors may need to be considered, (see Section 4.3.3 and Appendix H).

The formulae and calculations are sufficiently accurate for use at 11 kV and 33 kV on radial circuits. Circuit factors have not been included for 66 kV cables; however, a first estimate for these cables can be made using a similar 33 kV cable.

At 132 kV, the formulae and calculations are sufficiently accurate for use in feasibility studies, especially for single end fed cable circuits. They will normally provide conservative results. This is because the circuit factors calculated are for the cable construction that provides the highest ground return current, due for example to having the highest longitudinal sheath impedance and/or weakest mutual impedance between the faulted and return conductors. This would result from a cable with the smallest cross section area of sheath or the least conductive material (such as all lead rather than composite, aluminium or stranded copper) and thicker insulation (older type cables which consequently have a slightly weaker mutual coupling between the core and sheath). If further refinement or confidence is required, the circuits should be modelled with the appropriate level of detail and the work would normally show that a lower ground return current is applicable (i.e. more current returning via the cable screens or metallic routes.)

The formulae and calculations cater for simple overhead line circuits where there is no associated earth wire. For steel tower supported circuits that have an over-running earth wire, account is made of the induced current return by using Table E.1. Circuits that contain both underground cable and earthed overhead tower line construction are not presently addressed and need to be analysed on a case-by-case basis.

4.3.3 Amending calculations to account for increased ground return current in single-core circuits that are not in trefoil touching arrangement

The fault current calculations described in this document for single-core cable have assumed that the cables are earthed at each end and in touching trefoil formation.

In many practical situations, the cables are separated by a nominal distance, either deliberately (to reduce heating effects) or inadvertently (for example when installed in separate ducts).

When the distance between the individual cables is increased, the coupling between the faulted and other two cables is reduced. This in turn results in more current flowing through the local electrodes and an increase in the EPR at each point.

Some fault current studies for 11 kV and 132 kV cables where the cables are in touching trefoil, touching flat or the spacing is $3 \times D$ (i.e. $3 \times$ the cable diameter) are given in Appendix H.

For a flat arrangement of $3 \times D$ spacing, the ground return current is seen to increase compared to touching trefoil. Accordingly, if the cables are not touching, the ground return current and EPR may be adjusted using the information in Appendix H or through more detailed analysis.

5 EPR impact calculations

5.1 Calculation of touch potentials

When developing formulae for calculating the value of touch potentials, it is normal practice to refer these calculations to the potential of the natural ground surface of the site. From the safety aspect these calculated values are then compared with the appropriate safe value given in ENA TS 41-24 which takes account of any footwear or ground covering resistance (e.g. chippings, concrete etc.). It is important, therefore, to appreciate that the permissible safe value of touch potential, as calculated in this section, will differ depending on the ground covering, fault clearance time and other factors prevailing at the site.

The developed formulae are not rigorous but are based on the recognised concept of integrating the voltage gradient, given by the product of soil resistivity and current density through the soil, over a distance of one metre. Experience has shown that the maximum values of touch potential normally occur at the external edges of an earth electrode. For a grid electrode, this potential is increased by the greater current density transferring from the electrode conductors to ground around the periphery of the grid as compared with that transferring in the more central parts. These aspects have been taken into account in the formulae firstly for touch potential and secondly for the length of electrode conductor required to ensure a given touch potential is not exceeded.

Formulae are given in Appendix B for the following:

- External touch potential at the edge of the electrode (separately earthed fence) – Formula P1.
- External touch potential at the fence (separately earthed fence) – Formula P2.
- External touch potential at fence where there is no external perimeter electrode (bonded fence arrangement) – Formula P1.
- External touch potential at fence with external perimeter electrode 1 m away (bonded fence arrangement), buried 0.5m deep – Formula P3.
- Touch potential within substation earth grid – Formula P4.

5.2 Calculation of step potentials

The step potential is the potential difference between two points that are 1 m apart. This can be derived as the difference in calculated surface potential between two points that are 1 m apart (Formula P5). Note that this formula loses accuracy within a few metres of the grid.

5.3 Surface potential contours

The EPR at the substation creates potentials in the soil external to the substation. Formula P7 can be used to provide an estimate of the distance to the contour of interest.

As emphasised elsewhere in this document, this and other formulae are restricted in accuracy by their assumptions of a symmetrical electrode grid and uniform soil resistivity. More accurate plotting of contours is possible using computer software or site measurements.

5.4 Transfer potential to LV systems where the HV and LV earthing are separate

5.4.1 Background

This issue predominantly concerns distribution substations (typically 11 kV/400 V in the UK) where the HV and LV earthing systems are separate. Another application is where an LV earthing system is situated within the zone of influence of a primary substation with a high EPR. Previous

guidance was based upon the presence of a minimum 'in ground' separation between the two electrode systems being maintained (distances of between 3 m and 9 m have historically been used in the UK). Operational experience suggested that there were fewer incidents than would be expected when the separation distance had been encroached on with multiply earthed (i.e. TNC-S or PME) arrangements. Theoretical and measurement studies [1] showed that the minimum separation distance is a secondary factor, the main ones being the size and separation distance to the dominant or average LV electrode (where there are many small electrodes rather than one or a few large ones). This is referred to as the 'centre of gravity' of the LV electrode system.

Further information, together with worked examples is given in Appendix I.

See also Section 9.7.1 of ENA TS 41-24.

5.4.2 Basic theory

Formula P6 may be used to calculate the surface potential a given distance away from an earth electrode. Three different electrode shapes are included as follows:

- A hemispherical electrode at the soil surface.
- A vertical earth rod.
- An earth grid – approximated to a horizontal circular plate.

The surface potential calculated at a point using these formulae is equal to the transfer potential to a small electrode located at that point because an isolated electrode would simply rise to the same potential as the surrounding soil.

When two or more electrodes are connected together, previous investigations have shown that the transfer potential on the combined electrode is an average of the potential that would exist on the individual components. This average was found to be skewed towards the surface potentials on 'dominant' electrodes, i.e. those having a lower earth resistance due mainly to being larger.

A simple method is required to explain and then account for this 'averaging' effect. Figure 3 shows a simple arrangement of a HV earth electrode and two nearby LV earth rods (A and B) which are representative of typical PME electrodes.

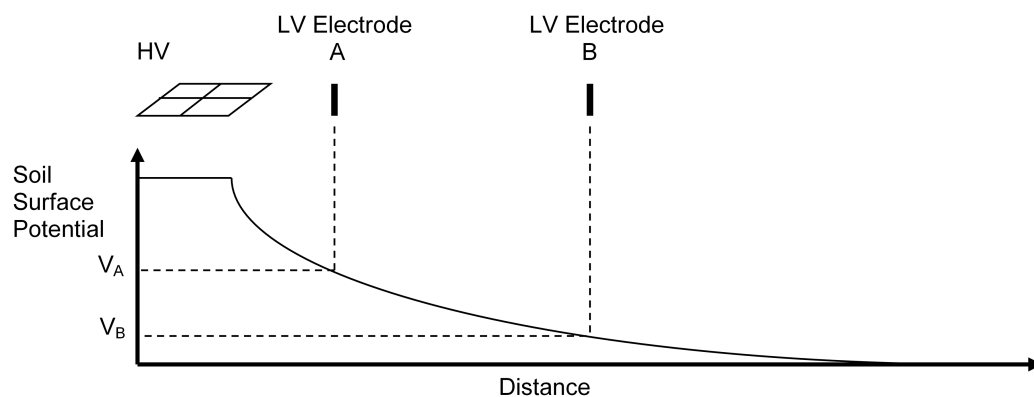

Figure 3 — Surface potential near a simple HV and LV electrode arrangement

The three electrodes are located along a straight line and the soil surface potential profile along this route is also approximated in the figure.

When there is an EPR on the HV electrode, the LV electrodes A and B will rise to the potential of the local soil, i.e. the surface potential. These potentials are defined as V_A and V_B . A and B are clearly at different potentials and this depends on the distance away from the HV electrode.

Once A and B are connected together (for example by the sheath / neutral of an LV service cable) the potential on them will change to an average value, between V_A and V_B . In simple cases where A and B are of a similar size (with the same earth resistance in soils of similar resistivity), the average potential is accurate but where electrodes A and B are of significantly different sizes the average is skewed towards the dominant one (the larger one, i.e. that has the lowest earth resistance).

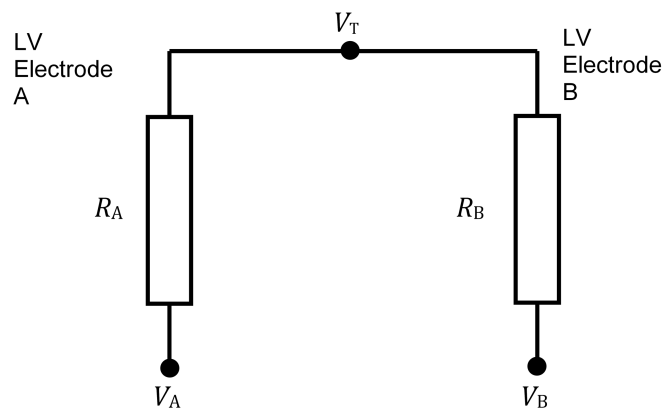

Figure 4 — Equivalent circuit for combined LV electrodes A and B

The averaging effect can be explained by considering an equivalent circuit for the combined LV electrodes as shown in Figure 4. V_A and V_B are the local soil surface potentials and V_T is the overall potential on the combined LV electrode. Electrodes A and B have earth resistances of R_A and R_B respectively.

The circuit is a potential divider and the voltage on the combined LV electrode (V_T) can be expressed by:

$$V_T = \frac{V_A R_B + V_B R_A}{R_A + R_B}$$

If the LV electrode earth resistances are equal ($R_A = R_B$) then this formula reduces to $V_T = \frac{V_A + V_B}{2}$

i.e. the average of the two potentials.

Worked examples are given in Appendix I.

5.5 Methods of optimising the design

Where the EPR is sufficient to create issues within or external to the substation, the following should be investigated and the most practicable considered for implementation.

5.5.1 More accurate evaluation of fault current

The contribution of fault resistance and longitudinal circuit impedance, and the appropriateness of factors used for fault current growth should be considered.

For example, it may be more prudent to use the existing value and implement additional measures later, i.e. at the same time as the predicted increase in fault current.

5.5.2 Reducing the overall earth impedance

Consideration should be given to whether an additional horizontal electrode could be incorporated with new underground cable circuits. The contribution of any PILCSWA type cables in the vicinity should be considered.

5.5.3 Reducing the touch potential within the installation

Consideration should be given to whether rebar or other non-bonded buried metalwork could be connected to the electrode system, whether other measures (such as physical barriers or isolation) could be applied, and whether the areas of high touch potential are accessible.

5.6 Risk assessment methodology

The risk assessment process is described in detail in ENA TS 41-24. It should be used as a last resort only, and needs to be justified, e.g. when achieving safe (deterministic) touch and step potentials is not practicable and economical. In practice, it is most appropriate outside an installation as it should almost always be possible to achieve safe (deterministic) step and touch voltages within site boundaries.

The individual risk of fatality per year (IR) for a hypothetical person¹ is calculated from the mean number of significant EPR events (f_n) per annum, the probability of exposure (P_E) and the probability of fibrillation (P_{FB}). A simplified formula applicable to power system applications is:

$$IR \cong f_n * P_E * P_{FB}$$

P_E and P_{FB} are dimensionless quantities; P_E relates to the proportion of time that an individual is in contact with the system, e.g. 1 hour per year is $1/(365*24) = 1.14 \times 10^{-4}$. P_{FB} can be derived from body current calculations and fault clearance times, with reference to Figure 20 of DD IEC/TS 60479-1. When between lines e.g. C1 and C2, the assessment should in the first instance use the higher P_{FB} for the band (e.g. 5% for the 0-5% band AC-4.1 between lines C1 and C2). An interpolated rather than upper-bound P_{FB} may be justifiable in some circumstances.

It is recommended that the large area dry contact impedance model 'not exceeded for 5% of the population' is used (Table 1 of DD IEC/TS 60479-1) unless specific circumstances apply.

This methodology is most accurate when $f_n * P_E * P_{FB}$ is $\ll 1$ (e.g. low fault occurrence or low exposure per year or low probability of fibrillation or indeed low due to a combination of these factors). In any case when this is not satisfied the resultant calculated IR will be much greater than acceptable levels.

This simplified formula is in line with that presented in Annex NB of BS EN 50522.

The calculated individual risk is then compared to a broadly acceptable risk of death per person per year as defined in the HSE Document 'Reducing Risk Protecting People' (R2P2) [2]. If the risk is greater than 1 in 1 million (deaths per person per year), but less than 1 in 10000, this falls into the tolerable region and the cost of reducing risk should then be evaluated according to ALARP principles (as low as reasonably practicable) taking into account the expected lifetime of

¹ A hypothetical person describes an individual who is in some fixed relation to the hazard, e.g. the person most exposed to it, or a person living at some fixed point or with some assumed pattern of life [2]. To ensure that all significant risks for a particular hazard are adequately covered, there will usually have to be a number of hypothetical persons considered.

the installation and the HSE's present value for the prevention of a fatality (VPF) to determine the justifiable spend for mitigation.

Where the justifiable spend is significantly less than the cost of mitigation, risk assessment may justify the decision whether or not to take mitigating action. Mitigation may include (and is not limited to) new or relocated barriers/fences, insulating paint, earthing redesign, substation relocation, restricted access / signage, protection enhancements, reliability improvements, EPR reduction, insulated ground coverings or fault level modification.

6 Case study examples

The five case studies demonstrate the differences in complexity and design philosophies involved when moving from an unearthed overhead supplied installation with a single supply through to a distribution or transmission installation that has several sources of supply. All case studies demonstrate the new design facilities that are expected at a modern installation, together with use of the fault current analysis formulae available with this document.

6.1 Case study 1: 33 kV substation supplied via overhead line circuit

A new 33 kV substation is to be built as Substation B. It is supplied from Substation A via an unearthed wood pole supported line that terminates just outside the operational boundary of each substation. The new substation is assumed to consist of just three items of plant, (incoming, outgoing, and a power transformer), each on their own individual foundation slab. This is the most straightforward example to study and will be used to demonstrate both the modern design approach and methods of addressing touch potentials. See Figure 5.

The approach used can be applied to similar arrangements at a range of voltage levels from 6.6 kV to 66 kV. At 6.6 kV and 11 kV, the substation would generally occupy a smaller area than in the examples shown.

This example considers a 33 kV earth fault at Substation B on the incoming line termination as shown in the diagram below.

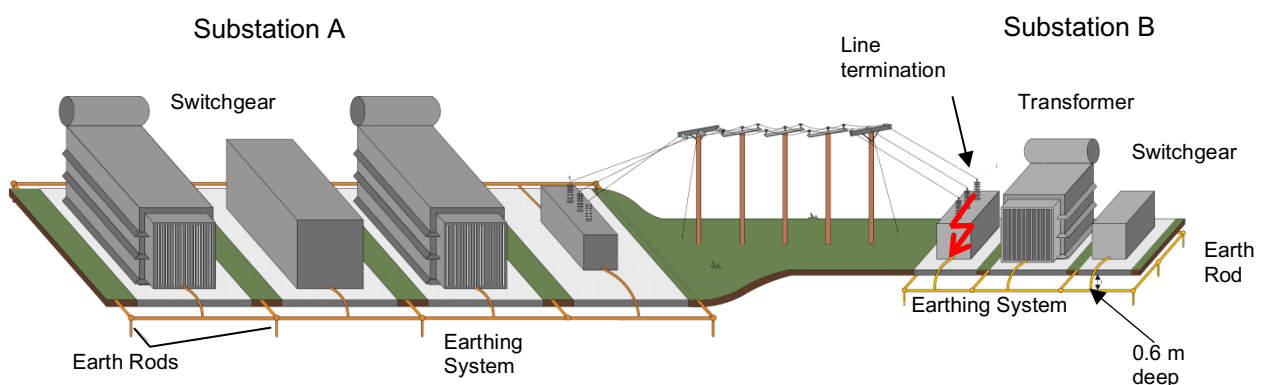

Figure 5 — Case study 1: Supply arrangement

For simplicity, all electrodes are assumed to be copper and have an equivalent circular diameter of 0.01 m (the electrical properties of steel could be used for the reinforcing material). The soil resistivity is $75 \Omega \cdot \text{m}$ and the 33 kV fault current magnitude is limited to a maximum of 2 kA by a neutral earth resistance connected to the 33 kV winding neutral at Substation A.

Substation A is assumed to be an overhead fed 132/33 kV substation with a measured earth resistance of 0.25 Ω. The overhead line conductors between Substations A and B are assumed to be 185 mm² ACSR.

Table 1 gives the fault clearance time and associated permissible touch potentials (from ENA TS 41-24) for 33 kV earth faults at Substation B when fed from Substation A.

Table 1 — Fault clearance time and permissible touch potentials

33 kV fault clearance time (s)	Permissible touch potential U_{TP} (V) inside substation (75 mm chippings)	Permissible touch potential U_{TP} (V) outside substation (on soil)
0.4	944	837

6.1.1 Resistance calculations

For this case, the land area is assumed to be fixed. The first calculation assumes a minimum earthing system consisting of a perimeter electrode 1 m outside the foundation slabs and two cross members in-between the slabs (Figure 6). For the next iterations, ten vertical 3.6 m rods are added (Figure 7) and then some horizontal rebar within each foundation slab (Figure 8).

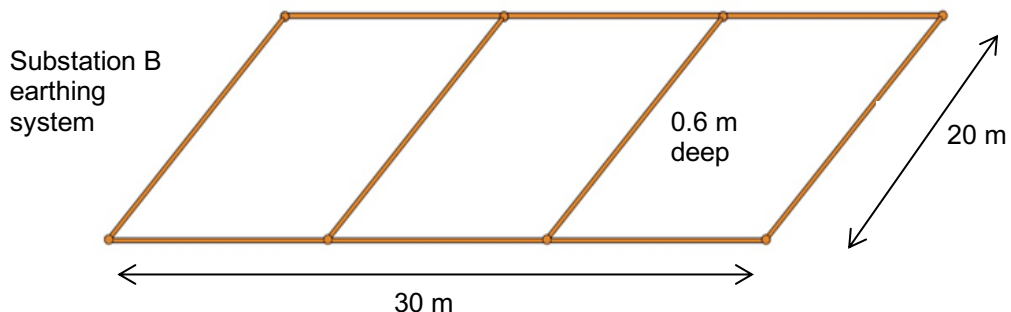

Figure 6 — Substation B basic earth grid

Using formula R4:

$$R_E = \frac{\rho}{4r} + \frac{\rho}{L_E}$$

Where L_E = length of buried conductor (not including rods).

$$r = \sqrt{\frac{A}{\pi}}$$

A = area of grid.

Substituting:

$$R_E = \frac{75}{4r} + \frac{75}{140}$$

Where:

$$r = \sqrt{\frac{A}{\pi}} = \sqrt{\frac{600}{\pi}} = 13.8$$

$$R_E = \frac{75}{55.3} + \frac{75}{140}$$

$$R_E = 1.89 \Omega$$

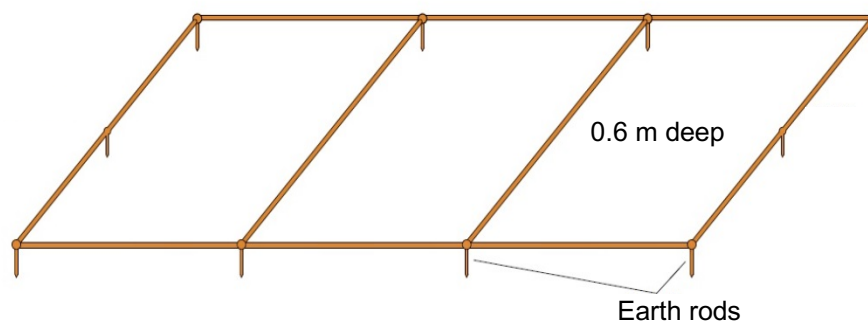

Figure 7 — Substation B basic earth grid and rods

Adding the ten rods as below, each of 3.6 m length and 16 mm diameter, requires the use of the more detailed formula.

Using formula R6:

$$R_E = \frac{R_1 R_2 - R_{12}^2}{R_1 + R_2 - 2R_{12}}$$

NOTE: This formula may not be valid for unconventional geometries, in which case computer modelling should be used.

Using formulae R4 to R6:

$$R_1 = R_{ES} = \frac{\rho}{4r} + \frac{\rho}{L_E}$$

L_E = length of horizontal electrode (m)

$$R_R = \frac{\rho}{2\pi L_R} \left(\log_e \frac{8L_R}{d} - 1 \right)$$

L_R = rod length (m)

d = diameter. Valid for $d \ll L_R$

$$R_2 = R_{ER} = R_R \left(\frac{1 + k\alpha}{N} \right)$$

$$\alpha = \frac{\rho}{2\pi R_R s}$$

$$r = \sqrt{\frac{A}{\pi}}$$

A = area of grid (m²)

N = total number of rods

k = 4.9 for 10 rods (From Figure B.1)

s = separation distance between rods (m)

$$R_{12} = R_1 - \frac{\rho}{\pi L_E} \left(\log_e \frac{L_R}{b} - 1 \right)$$

b = equivalent diameter (m) of the circular earth electrode or the width of a tape electrode.

$$R_E = \frac{R_1 R_2 - R_{12}^2}{R_1 + R_2 - 2R_{12}}$$

Therefore:

$$R_1 = \frac{75}{4 \times 13.82} + \frac{75}{140} = 1.89 \Omega$$

$$R_R = \frac{75}{2\pi \times 3.6} \left(\log_e \left(\frac{8 \times 3.6}{0.016} \right) - 1 \right) = 21.6 \Omega$$

$$\alpha = \frac{75}{2\pi \times 21.6 \times 10} = 0.055$$

$$R_2 = 21.6 \times \left(\frac{1 + 4.9 \times 0.055}{10} \right) = 2.74 \Omega$$

$$R_{12} = 1.89 - \frac{75}{\pi \times 140} \left(\log_e \frac{3.6}{0.01} - 1 \right) = 1.06 \Omega$$

$$R_E = \frac{1.89 \times 2.74 - 1.06^2}{1.89 + 2.74 - 2 \times 1.06} = 1.62 \Omega$$

As can be seen, the rods have reduced the resistance to 1.62 Ω compared to 1.89 Ω without rods.

For the final calculation, the re-bar within the horizontal foundations has been approximated by the symmetrical meshes shown in Figure 8. For simplicity it is assumed that they have the same equivalent circular diameter as the copper conductor and the same electrical properties (see NOTE below).

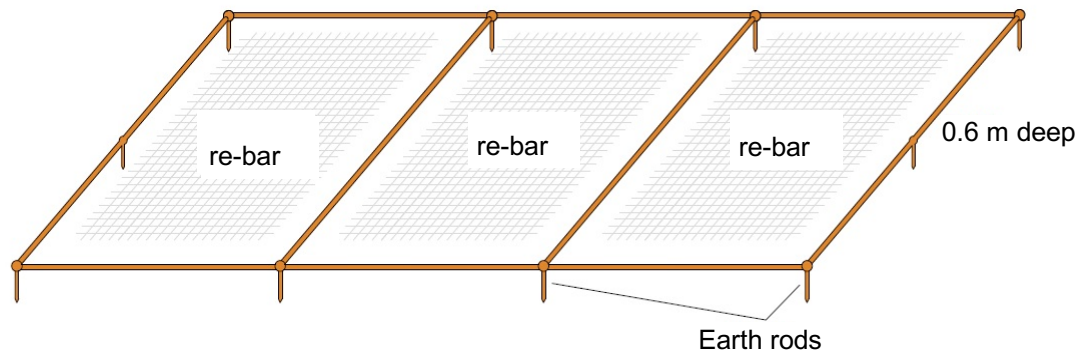

Figure 8 — Substation B earth grid with rods and re-bar

The same formula and approach is used as previously, except that the length of conductor is increased to include the amount of re-bar modelled (786 m total of re-bar added to that of copper).

Using formula R6:

$$R_E = \frac{R_1 R_2 - R_{12}^2}{R_1 + R_2 - 2R_{12}}$$

NOTE: For a more detailed analysis, the equivalent diameter of the different electrodes and their electrical properties and orientation would be included. In the majority of cases, this would require the use of a computer simulation package. In this case, computer modelling gives a resistance of 1.25 Ω for the grid in Figure 8 (compared with 1.43 Ω as calculated below).

Using Formulae R4 to R6:

$$R_1 = R_{ES} = \frac{\rho}{4r} + \frac{\rho}{L_E}$$

$$R_R = \frac{\rho}{2\pi L_R} \left(\log_e \frac{8L_R}{d} - 1 \right)$$

$$R_2 = R_{ER} = R_R \left(\frac{1 + k\alpha}{N} \right)$$

$$\alpha = \frac{\rho}{2\pi R_R s}$$

$$R_{12} = R_1 - \frac{\rho}{\pi L_E} \left(\log_e \frac{L_R}{b} - 1 \right)$$

$$R_E = \frac{R_1 R_2 - R_{12}^2}{R_1 + R_2 - 2R_{12}}$$

Therefore:

$$R_1 = \frac{75}{4 \times 13.82} + \frac{75}{926} = 1.44 \Omega$$

$$R_R = \frac{75}{2\pi \times 3.6} \left(\log_e \left(\frac{8 \times 3.6}{0.016} \right) - 1 \right) = 21.6 \Omega$$

$$\alpha = \frac{75}{2\pi \times 21.6 \times 10} = 0.055$$

$$R_2 = 21.6 \times \left(\frac{1 + 4.9 \times 0.055}{10} \right) = 2.74 \Omega$$

$$R_{12} = 1.44 - \frac{75}{\pi \times 926} \left(\log_e \frac{3.6}{0.01} - 1 \right) = 1.31 \Omega$$

$$R_E = \frac{1.44 \times 2.74 - 1.31^2}{1.44 + 2.74 - 2 \times 1.31} = 1.43 \Omega$$

L_E = length of horizontal electrode (m)

L_R = rod length (m)

d = diameter. Valid for $d \ll L_R$

$$r = \sqrt{\frac{A}{\pi}}$$

A = area of grid (m²)

N = total number of rods

k = 4.9 for 10 rods (From Table B.1)

s = distance between rods (m)

b = equivalent diameter (m) of the circular earth electrode or the width of a tape electrode

This gives a slightly lower resistance of 1.43 Ω .

6.1.2 Calculation of fault current and earth potential rise

The maximum 33 kV earth fault current is limited to 2 kA by a neutral earthing resistor. The fault current is further attenuated by the electrode resistances at Substation A and B together with the longitudinal impedance of the overhead line phase conductors. System X/R ratios are neglected for simplicity. Table 2 gives the fault current and EPR corresponding to the earth resistances calculated in Section 6.1.1.

Table 2 — EPR for different grid arrangements

Arrangement	Resistance (Ω)	Earth fault current I_{ES} at Substation B* (A)	EPR (V)
Basic grid	1.89	1447	2735
Grid & rods	1.62	1477	2393
Grid, rods & rebar (using formulae)	1.43	1499	2144
Grid, rods & rebar (using computer software for comparison)	1.25	1521	1901
<p>* For simplicity this has been calculated using an equivalent single-phase circuit including the earth resistance at Substation A (0.25 Ω), NER value (9.53 Ω), circuit impedance (1.5 Ω) and the earth resistance at Substation B from the table. These values would normally be available from power system short-circuit analysis software.</p> <p>NOTE: Because there is an unearthed overhead line supply, the calculated earth fault current is equal to the ground return current in this example.</p>			

The addition of the rods and rebar have each reduced the resistance and EPR, but not dramatically. The site has an EPR that exceeds twice the permissible touch voltage U_{TP} . It is therefore necessary to calculate the touch potentials and to compare these to permissible values.

6.1.3 Calculation of touch potentials

Formula P1 estimates the touch potential one metre beyond the perimeter electrode. It is usually the case that provided the internal electrode has been correctly designed (with sufficient meshes), the touch potential here will exceed that anywhere within the grid area. Where the internal mesh is large the internal touch voltage at the centre of the corner mesh may be approximated using formula P4. For unusually shaped or non-symmetrical grids, computer software tools are needed for an accurate calculation.

The calculation procedure is outlined below.

For simplicity, the grid without foundation re-bar is used, as in Figure 7. A single cross-member is added later to give an initial estimate of the effect of the re-bar.

6.1.4 External touch potential at the edge of the electrode

Using formula P1:

$$U_T = \frac{k_e \cdot k_d \cdot \rho \cdot I_E}{L_T}$$

$$k_e = \frac{1}{\pi} \left(\frac{1}{2} \log_e \frac{h}{d} + \frac{1}{2h} + \frac{1}{(0.5 + D)} + \frac{1}{D} (1 - 0.5^{n-2}) \right)$$

$$h = 0.6 \text{ m}, d = 0.01 \text{ m}$$

$$D = \text{average spacing between parallel grid conductors} = (20 \text{ m} + 10 \text{ m})/2 = 15 \text{ m}$$

$$n = (n_A \cdot n_B)^{1/2}$$

$$\text{Where } n_A = 2, n_B = 4$$

$$k_e = \frac{1}{\pi} \left(\frac{1}{2} \log_e \frac{0.6}{0.01} + \frac{1}{2 \cdot 0.6} + \frac{1}{(0.5 + 15)} + \frac{1}{15} (1 - 0.5^{\sqrt{2 \cdot 4} - 2}) \right) = 0.946$$

k_d is a factor which modifies k_e to allow for non-uniform distribution of electrode current and is given by:

$$k_d = \left(0.7 + 0.3 \frac{L_T}{L_p} \right)$$

Where:

L_T = total length of buried electrode conductor **including rods** if connected (176 m)

L_p = length of perimeter conductor **including rods** if connected (136 m)

$$\rho = 75 \Omega \cdot \text{m}$$

I_E = total current passing to ground through electrode (1477 A)

$$k_d = \left(0.7 + 0.3 \frac{176}{136} \right) = 1.088$$

$$U_{T(\text{grid})} = \frac{0.946 \cdot 1.088 \cdot 75 \cdot 1477}{176} = 648 \text{ V}$$

This reduces to 602 V if an additional central cross member is added along the x axis (this adds 30 m of electrode and provides a uniform separation between mesh conductors in each direction of 10 m).

Where there are more cross members or to account for the re-bar, the additional conductors are accounted for in the formula in a similar process to that above and will provide a lower touch potential.

For comparison purposes, when the grids are modelled using computer software, the touch potentials are:

- Basic grid (plus rods), touch potential 1 m from the edge of the grid varies from 24 % of the EPR at the centre of one of the sides to 33 % at the corner. For the calculated EPR of 2393 V this equates to touch potentials of between 574 V and 790 V.
- With re-bar included, the touch potential 1 m from the edge of the grid varies from 18 % of the EPR at the centre of one of the sides to 28 % at the corner. For the calculated EPR of 2144 V this equates to touch potentials of between 386 V and 600 V. These are all significantly lower than the permissible touch voltage of 944 V (Table 1). Since the EPR exceeds the ENA TS 41-24 'high EPR' threshold, any LV supplies taken from site (or brought in) would need to be separately earthed (see ENA TS 41-24 section 9). Telecoms circuits will need similar consideration and the use of isolating units etc. as appropriate.

6.1.5 Touch potential on fence

If a metal fence is present at 2 m outside the electrode system and independently earthed in accordance with ENA TS 41-24, the touch potential 1 m external to the fence can be calculated by substituting the variables into formula P2 and is 169 V.

6.1.6 Internal touch potentials

The touch potential inside the substation earth grid (at the centre of the corner mesh) for the arrangement with grid and rods only may be calculated using formula P4 as 657 V.

For comparison, when this arrangement is simulated using computer software, the touch potential in the same location is 30 % of the EPR. For the calculated EPR of 2393 V, this equates to a touch potential of 718 V.

As would be expected inside the grid, addition of the re-bar has a significant effect and the calculated touch potential from formula P4 reduces to 158 V.

6.1.7 Calculation of external voltage impact contours

This requires use of formula P7 (note that calculations are in radians). This formula is a re-arrangement of Formula P6.3 to provide the distance from the outer edge of the earth grid to a set potential point in relation to the EPR that has already been calculated.

The procedure to determine the distance x from the edge of the earth grid to the V_x contour is as below:

$$x = \sqrt{\frac{A}{\pi} \left[\left(\sin \frac{V_x \times \pi}{2 \times \text{EPR}} \right)^{-1} - 1 \right]}$$

E.g. for a protection clearance time of 0.6 seconds, it may be necessary to find the contour where the voltage is $2 \times U_{TP}$ (840 V). Substituting the values for A (600 m²) and the EPR (2393 V):

$$x = \sqrt{\frac{600}{\pi} \left[\left(\sin \frac{840 \times \pi}{2 \times 2393} \right)^{-1} - 1 \right]} = 12.5 \text{ m}$$

Similar calculations would be carried out for other contours of interest. It is important to note that these calculations only apply with a reasonable degree of accuracy to a grid that is close to a square shape, in uniform soil and for distances greater than a few metres from the edge of the grid. For irregular shaped grids, such as one with radial spurs, a computer simulation or actual site measurement is necessary for sufficient accuracy.

6.2 Case study 2: 33 kV substation supplied via cable circuit

In this example, the situation is identical to that of case study 1, except that the circuit between the substations is 3 km of underground cable.

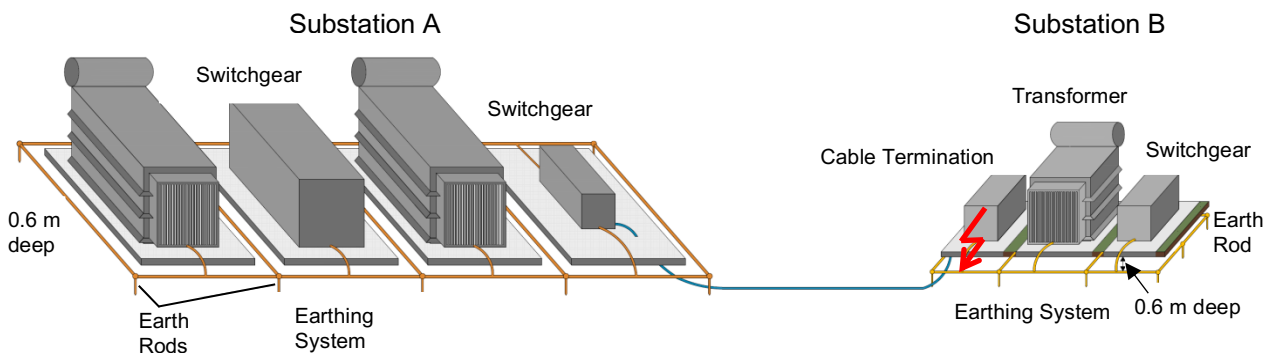

Figure 9 — Case study 2: Supply arrangement

For simplicity, all electrodes are assumed to be copper and have an equivalent circular diameter of 0.01 m (the electrical properties of steel could be used for the reinforcing material). The soil resistivity is $75 \Omega \cdot \text{m}$ and the 33 kV fault current magnitude is limited to a maximum of 2 kA by a neutral earth resistance connected to the 33 kV winding neutral at Substation A.

Substation A is assumed to be an overhead fed 132/33 kV substation with a measured earth resistance of 0.25Ω . The underground cables between Substation A and B are assumed to be $3 \times 185 \text{ mm}^2$ single-core (triplex) cables. Relevant parameters, including self and mutual impedances and C-factors for this cable type are given in Table D.2.

Table 3 gives the fault clearance time and associated permissible touch potentials for 33 kV earth faults at Substation B when fed from Substation A.

Table 3 — Fault clearance time and permissible touch potentials

33 kV fault clearance time (s)	Permissible touch potential U_{TP} inside substation (V) (75 mm chippings)	Permissible touch potential U_{TP} outside substation (V) (on soil)
0.4	944	837

6.2.1 Resistance calculations

The resistance calculations are identical to those completed for case study 1 and the initial analysis will focus on the values that include the re-bar and vertical earth rods (1.43Ω from Table 2).

6.2.2 Calculation of fault current and EPR

The 33 kV earth fault current is limited to a maximum of 2 kA by a neutral earthing resistor. The fault current is further attenuated by the underground cable impedance. The underground cable circuit has a lower longitudinal phase impedance compared to an overhead line arrangement of the same dimension and type, hence the earth fault current of 1896 A calculated at Substation B is higher than seen previously in case study 1.

To calculate the ground return current I_E for cable circuits (triplex or three-core), it is necessary to use either the simplified C-factor approach outlined below, or matrix formulae. Both approaches are demonstrated below:

6.2.3 C-factor method

This arrangement (all cable circuit) shown in Figure D.1.

The appropriate value of C for 33 kV 185/35 mm² cable in this arrangement is 77 (from Table D.2).

$$I_E = I_F \times \frac{\frac{C}{(a + 9E)}}{\sqrt{\left\{ \left(\frac{C}{a + 9E} + \frac{R_{AB}}{\ell} \right)^2 + 0.6 \left(\frac{\rho}{aE} \right)^{0.1} \right\}}}$$

Table 4 — Input data and results

Parameter	Value
E	33 kV
ρ	75 $\Omega \cdot m$
a	185 mm ²
C	77 (from Table D.2)
R_A	0.25 Ω
R_B	1.43 Ω
$R_{AB} = R_A + R_B$	1.68 Ω
ℓ	3 km
I_F	1896 A
I_E %	16.8 %
I_E	318 A
EPR_B	455 V

6.2.4 Matrix method

This method is appropriate where cable physical parameters are available. Self and mutual impedance values can be determined from data provided by manufacturers (or from measurements) and by using formulae given in Appendix D.

NOTE: In most cases it will be necessary to work with manufacturer's cable data that is characterised at 20 °C. For heavily loaded circuits (close to 90 °C), the sheath and core resistances will increase. This could be significant in marginal situations and should be considered as necessary.

From Table D.2:

$Z_C = 0.87 \angle 51.8^\circ$ (sheath self-impedance) and $z_{mp,C} = 0.683 \angle 85.86^\circ$ (sheath-sheath and sheath-core mutual impedances) which when expressed in complex form gives the values in Table 5.

Table 5 — Complex representation of cable self and mutual impedances

Parameter	Value (Ω)	Description
$Z_{C1} = Z_{C2} = Z_{C3}$	$0.542 + 0.681j$	Cable sheath impedance
$z_{m1,2} = z_{m1,3} = z_{m2,3}$ (NOTE 1)	$0.049 + 0.628j$	Mutual impedance between sheaths
$z_{mp,1}$ (NOTE 2)	$0.049236 + 0.628j$	Mutual impedance between faulty core and faulty sheath
$z_{mp,2} = z_{mp,3}$	$0.049233 + 0.628j$	Mutual impedance between faulty core and healthy sheath

NOTE 1: The three terms shown will not be equal if the cable layout is non-trefoil. See Appendix H.

NOTE 2: $z_{mp,1} \approx z_{mp,2} \approx z_{mp,3} \approx z_{m1,2}$ etc. for close formation triplex and may be assumed if detailed modelling data is not available.

From D.3.1:

$$\begin{bmatrix} (R_A + \ell z_{c1} + R_B) & (R_A + \ell z_{m1,2} + R_B) & (R_A + \ell z_{m1,3} + R_B) \\ (R_A + \ell z_{m1,2} + R_B) & (R_A + \ell z_{c2} + R_B) & (R_A + \ell z_{m2,3} + R_B) \\ (R_A + \ell z_{m1,3} + R_B) & (R_A + \ell z_{m2,3} + R_B) & (R_A + \ell z_{c3} + R_B) \end{bmatrix} \begin{bmatrix} I_1 \\ I_2 \\ I_3 \end{bmatrix} = -I_F \begin{bmatrix} (R_A + \ell z_{mp,1} + R_B) \\ (R_A + \ell z_{mp,2} + R_B) \\ (R_A + \ell z_{mp,3} + R_B) \end{bmatrix}$$

Rearranging:

$$\begin{bmatrix} I_1 \\ I_2 \\ I_3 \end{bmatrix} = \begin{bmatrix} (R_A + \ell z_{c1} + R_B) & (R_A + \ell z_{m1,2} + R_B) & (R_A + \ell z_{m1,3} + R_B) \\ (R_A + \ell z_{m1,2} + R_B) & (R_A + \ell z_{c2} + R_B) & (R_A + \ell z_{m2,3} + R_B) \\ (R_A + \ell z_{m1,3} + R_B) & (R_A + \ell z_{m2,3} + R_B) & (R_A + \ell z_{c3} + R_B) \end{bmatrix}^{-1} \cdot -I_F \begin{bmatrix} (R_A + \ell z_{mp,1} + R_B) \\ (R_A + \ell z_{mp,2} + R_B) \\ (R_A + \ell z_{mp,3} + R_B) \end{bmatrix}$$

$$I_E = -I_F - I_1 - I_2 - I_3$$

Working with complex (vector) quantities throughout, and taking the magnitude of I_E as the result gives:

Table 6 — Resultant fault current distribution and EPR (matrix method)

Parameter	Value
I_E %	16.3 %
I_E	309 A
EPR_B	442 V

6.2.5 Results

It can be seen that both methods give a reasonable correlation ($I_{ES} = 318$ A vs 309 A); minor discrepancies will inevitably arise due to assumptions and approximations used with both methods. In this case the C-factor method predicts a slightly higher EPR, and this will be used in design calculations and discussion below.

A large proportion of the earth fault current returns via the cable sheaths. The current flowing through the 1.43Ω substation earth resistance creates an EPR of only 455 V (compared to 2144 V in case study 1), despite the higher overall fault current. The EPR is considerably lower than the permissible touch voltage, so no further calculations are necessary.

The worst conceivable situation would involve the loss of the sheath connections co-incident with the earth fault. (This is considered an unlikely event for triplex or three single-core circuits). The EPR would increase to a theoretical maximum of around 2711 V ($1.43 \Omega \times 1896$ A) [in practice the situation would be closer to 2144 V as calculated for Case Study 1 because the fault current would reduce]. However, the foundation re-bar and perimeter electrode would restrict the touch voltage to just 29 %, i.e. 621 V, which is much lower than the permissible touch voltage of 944 V on chippings. The site would still be compliant in terms of safety voltages, although there would now be a larger external zone with high surface potential.

6.3 Case study 3: 33 kV substation supplied via mixed overhead line/cable circuit

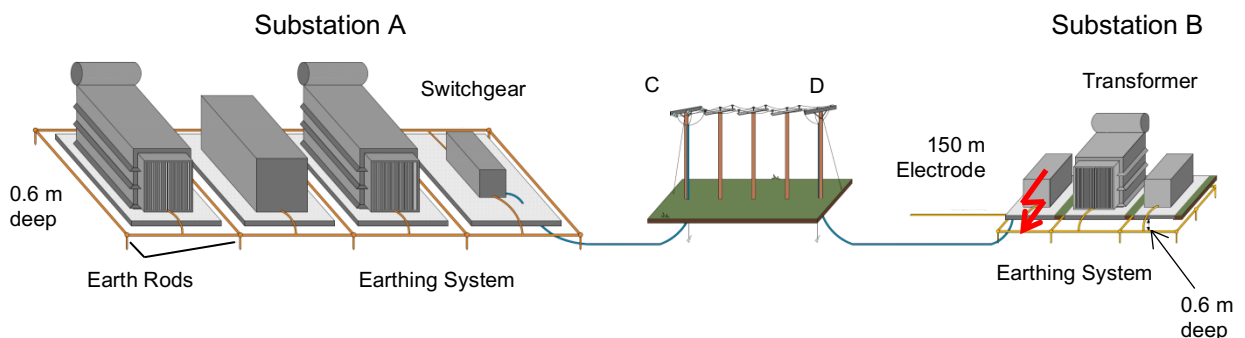

Figure 10 — Case study 3: Supply arrangement

This is a more complex example to demonstrate the issues involved in an area where there are towns or villages supplied from an overhead line network. This example shows a 33 kV supply but the arrangement is also very common at 11 kV; in both case an identical approach is used for analysis using appropriate cable data.

The circuit length remains at 3 km, with 500 m of cable at each end and 2 km of overhead line in the centre. The terminal poles at points C and D will have their own independent electrodes (rods and/or buried earth wire) and are assumed to each have an earth resistance of 10Ω for insulation co-ordination purposes.

6.3.1 Resistance calculations

The resistance of Substation B is the same as calculated previously for a soil resistivity of 75 Ω·m. However, as is common practice, the opportunity has been taken to install a buried earth wire with the incoming cable as shown. A length of 150 m is assumed and this will have a resistance that will act in parallel with that of the grid.

Resistance of horizontal electrode:

Using formula R7, noting that the conductor length is smaller than the limit of validity given in Table B.1:

$$R_H = \frac{\rho}{2\pi L_H} \left[\log_e \left(\frac{2L_H}{d} \right) \right]$$

depth of burial $h=0.6$, $d=0.00944$ m (approx. diameter of 70 mm² conductor)

The resistance of the earth wire is 0.82 Ω. The resistance of the earth grid is 1.43 Ω. In parallel, the combined resistance (ignoring proximity effects) is:

$$0.82 / 1.43 = 0.52 \Omega$$

When proximity effects are included, by using a computer simulation software, the calculated resistance value increases to 0.675 Ω.

6.3.2 Calculation of fault current and earth potential rise

The 33kV earth fault current is limited to a maximum of 2 kA by a neutral earthing resistor. The impedance of the overhead line and cable arrangement further attenuates the fault current at Substation B. The corresponding maximum earth fault current has been calculated to be 1594 A.

As this supply arrangement does not have a continuous metallic sheath back to the source, the ground return current is calculated for the two 500 m sections of cable either side of the overhead lines. The formulae from Appendix D and cable data in Table D.2 are used to calculate the fault current distribution as shown in Figure 11.

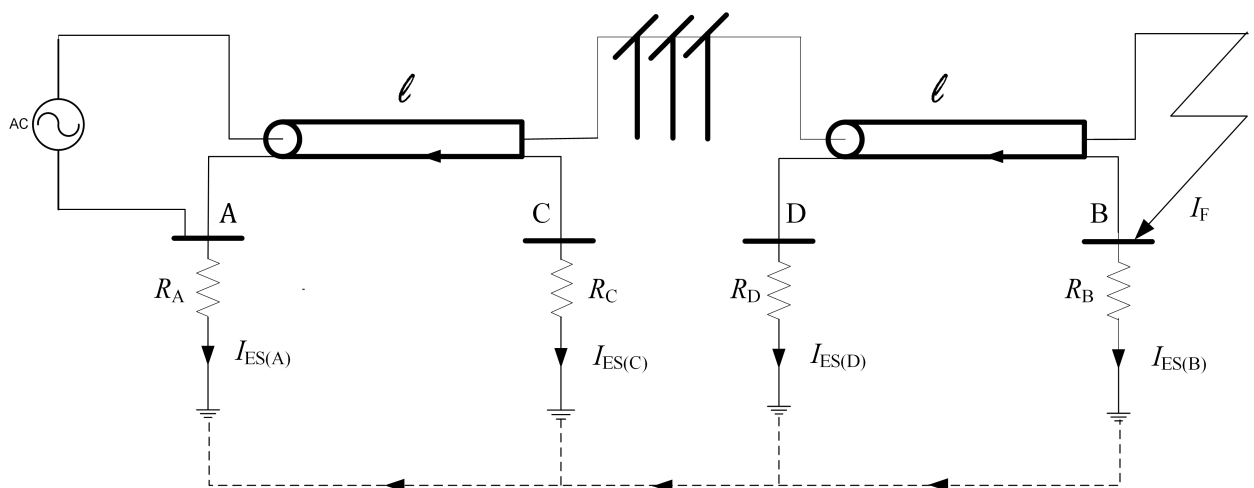

Figure 11 — Case study 3: Equivalent circuit

In this example, the C-factor formula given in D.4.3 can be used to give the current split between cable sheath return and ground return paths, from the perspective of substation B. The current

flows into soil (via R_B), and along the cable sheath (via R_D + the cable sheath impedance). R_D (10 Ω) is used in place of R_A in the formula. In this case,

$$I_{ES(B)} = I_F \times \frac{\frac{C}{(a + 9E)} + \frac{R_D}{\ell}}{\sqrt{\left\{ \left(\frac{C}{a + 9E} + \frac{R_{DB}}{\ell} \right)^2 + 0.6 \left(\frac{\rho}{aE} \right)^{0.1} \right\}}}$$

Results are shown in Table 7.

Table 7 — Input data and results for final part of circuit

Parameter	Value
E	33 kV
ρ	75 $\Omega \cdot m$
a	185 mm ²
C	67 (from Table D.2)
R_D	10 Ω
R_B	0.675 Ω
$R_{DB} = R_D + R_B$	10.675 Ω
ℓ	0.5 km
I_F	1594 A
$I_{ES(B)}\%$	93.6 %
$I_{ES(B)}$	1493 A
EPR_B	1008 V
$I_{ES(D)}$	101 A
EPR_D	1010 V

As shown in Table 7, 93.6 % of the available fault current flows through R_B and creates an EPR of 1008 V. The remainder of the current returns via the cable sheaths and through the earth resistance at point D, creating a similar EPR at point D.

The companion C-factor formula given in D.4.2 can be used to calculate the EPR at the source substation (Substation A) and the first pole/cable interface at C for the same fault at Substation B. In this application, in the formula it is necessary to use R_C in place of R_B , and $R_{AC} = R_A + R_C$ in place of R_{AB} .

In this case,

$$I_{ES(C)} = I_F \times \frac{\frac{C}{(a + 9E)} + \frac{R_C}{\ell}}{\sqrt{\left\{ \left(\frac{C}{a + 9E} + \frac{R_{AC}}{\ell} \right)^2 + 0.6 \left(\frac{\rho}{aE} \right)^{0.1} \right\}}}$$

This shows that approximately 39.4 A is collected by the rod electrode at C, giving an EPR at C of $39.4 \times 10 = 394$ V.

The remainder of the current (1554.6 A) returns via the ground to the source where it flows through the 0.25Ω resistance R_A and creates an EPR at A of 389 V.

As shown in Table 8, the EPR at the source substation A is only 389 V. This is sufficiently low that the calculation of touch, step and external impact contours is not required. The EPR at Substation B exceeds the limits for soil and chipping surfaces, hence the calculation of touch, step and external impact contours is required.

Although the EPR at terminal pole D is relatively high (1010 V), this may not pose a touch potential hazard as the earth conductors on the pole are normally insulated.

Table 8 — Input data and results for initial part of circuit

Parameter	Value
E	33 kV
ρ	$75 \Omega \cdot \text{m}$
a	185 mm^2
C	67 (from Table D.2)
R_A	0.25Ω
R_C	10Ω
$R_{AC} = R_A + R_C$	10.25Ω
ℓ	0.5 km
I_F	1594 A
$I_{ES(A)} \%$	97.53 %
$I_{ES(A)}$	1554.6 A
EPR_A	389 V
$I_{ES(C)}$	39.4 A
EPR_C	394 V

6.4 Case study 4: Multiple neutrals

6.4.1 Introduction

In UK networks operating at voltages of 132 kV and above, the system neutral is generally solidly and multiply earthed. This is achieved by providing a low impedance connection between the star

point of each EHV transformer (primary) winding and each substation earth electrode. The low impedance neutral connection often provides a parallel path for earth fault current to flow and this reduces the amount of current flowing into the substation earth electrode. For EPR calculations in such systems, the neutral returning component of earth fault current should be considered. The current split between the different return paths in this study is shown by red arrows in Figure 12.

Circuits entering a substation are often via a mixture of overhead and underground cables. A high percentage of the earth fault current flowing in an underground cable circuit will return to source via the cable sheath if bonded at both ends (typically 70 % to 95 %), whereas in an earthed overhead line circuit the current flowing back via the aerial earth wire is a lower percentage (typically 30 % - 40 %). It is therefore necessary to apply different reduction factors to the individual currents flowing in each circuit. The individual phase currents on each circuit are required for these calculations.

The detailed fault current data required is normally available at transmission level from most network modelling software packages. Any additional calculation effort at an early stage is usually justified by subsequent savings in design and installation costs that result from a lower calculated EPR.

This case study has been selected to illustrate:

- Calculations to subtract the local neutral current in multiply earthed systems.
- The application of different reduction factors for overhead line and underground cable circuits.
- A situation where there are fault infeeds from two different sources.

Figure 12 shows a simplified line-diagram of an arrangement where a 132 kV single phase to earth fault is assumed at 132/33 kV Substation X. Two 132 kV circuits are connected to Substation X, the first is via an overhead line from a 400/132 kV Substation Y and the second is via an underground cable from a further 132/33 kV Substation Z which is a wind farm connection. There is a single transformer at Substation X and its primary winding is shown together with the star point connection to earth.

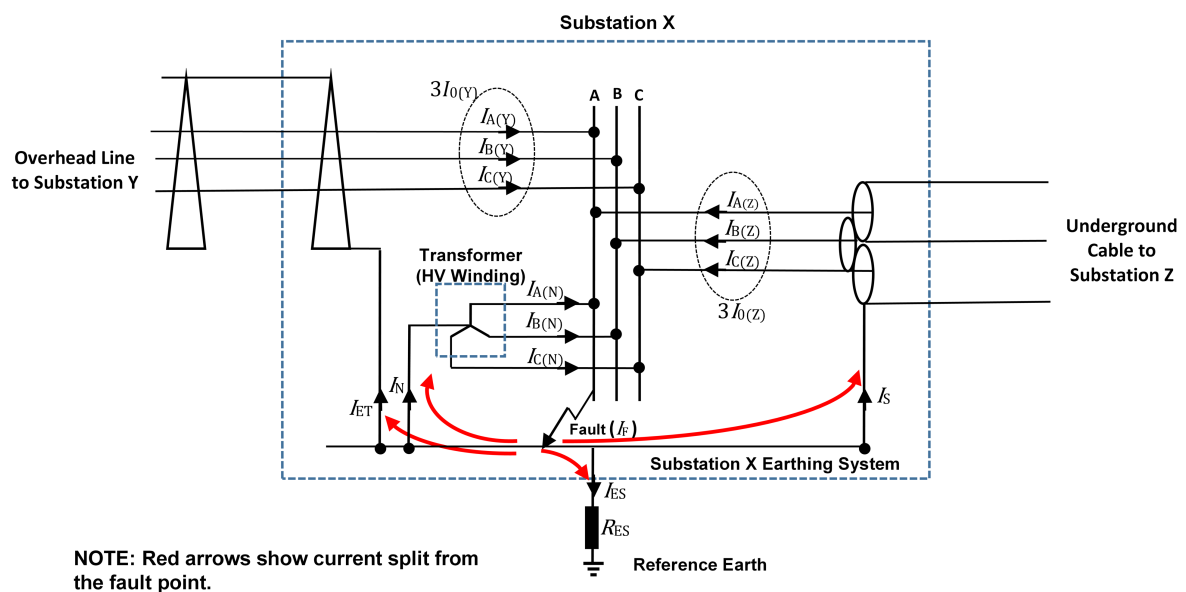

Figure 12 — Case study 4: Supply arrangement

6.4.2 Case study data

For the single phase to earth fault on Phase A illustrated in Figure 12, the individual currents flowing on each phase of each circuit and in the transformer HV winding are shown in Table 9. This data is typical of that from short-circuit software package used for transmission studies.

Table 9 — Case study 4: Short-circuit data

Single-phase to ground fault at Substation X							
From	$I_k''_A$ (kA)	$I_k''_A$ (deg)	$I_k''_B$ (kA)	$I_k''_B$ (deg)	$I_k''_C$ (kA)	$I_k''_C$ (deg)	$3I_0$ (kA)
Transformer (HV Side)	0.840	62.386	0.291	76.190	0.495	63.802	1.620
Substation Y	4.163	72.533	0.766	-135.761	0.598	-93.980	2.916
Substation Z	8.093	76.072	0.541	27.674	0.233	139.316	8.559
Sum of contributions into	$I_k''_A$ (kA)	$I_k''_A$ (deg)	$I_k''_B$ (kA)	$I_k''_B$ (deg)	$I_k''_C$ (kA)	$I_k''_C$ (deg)	
Substation X	13.071	74.074	0.000	0.000	0.000	0.000	
	U_A (kV)	U_A (deg)	U_B (kV)	U_B (deg)	U_C (kV)	U_C (deg)	
	0.000	0.000	86.916	-146.069	84.262	91.344	

6.4.3 Treatment of neutral current

In Table 9, the 'Sum of contributions into Substation X' is the vector sum of the faulted 'A' Phase contributions from the two lines and the transformer and is defined as the total earth fault current (I_F). The contribution shown as 'Transformer (HV Side)' represents the transformer star-point or 'neutral' current (I_N).

The current that returns to Substations Y and Z via Substation X earth Electrode (I_{ES}) is separate from that flowing back via the transformer neutral (I_N) and metallic paths (neutral and healthy phases). It can be shown that $I_F - I_N = 3I_0$ where $3I_0$ is the three times the sum of zero-sequence current on all lines connected to the substation. For each line, $3I_0$ is equal to the vector sum of the individual line phase currents, i.e. $3I_0 = I_A + I_B + I_C$.

Table 10 gives the calculated $3I_0$ values for each of the two lines and their sum.

Table 10 — Sum of contributions to earth fault current

Contribution from:	$3I_0$ magnitude (kA)	$3I_0$ angle (Deg)
Substation Y	2.916	76.9
Substation Z	8.559	74.8
Sum of Contributions from Y+Z	11.470	75.3

From Table 9 and Table 10 it can be seen that earth fault current magnitude of 13.07 kA calculated by the short-circuit software package reduces to 11.47 kA once the local neutral current is subtracted.

As a further check of this value, the sum of the currents flowing on the transformer (HV Side) can be subtracted from the total earth fault current calculated by the short-circuit software package to arrive at the same result, i.e. $13.07\angle 74^\circ - 1.62\angle 65.3^\circ = 11.47\angle 75.3^\circ$ (kA)

6.4.4 Fault current distribution

The circuit from Substation Y is via an overhead line, whereas that from Substation Z is via an underground cable. Further calculations are required to calculate the fault current distribution between the substation electrode, tower line earth wire and the underground cable sheaths.

Table 11 lists the additional information assumed for this case study.

The calculated reduction factors (r_E) for each circuit type from

Table 11 are applied to the three-times zero-sequence currents ($3I_0$) on each circuit and the total ground return current (I_E) is calculated. Results are given in Table 12.

The total ground return current magnitude (I_E) is shown to be only 1.5 kA which is significantly lower than the short-circuit current at the fault point (I_F) of 13.07 kA.

Table 11 — Information for fault current distribution calculations

Line construction between Substations X and Y	132 kV double circuit tower line L4 construction. 20 spans long.
Reduction factor for line between Substations X and Y	$0.708\angle -9^\circ$ (From Table E.1)
Line construction between Substations X and Z	132 kV, 3 x 1c, 300 mm ² aluminium conductor, 135 mm ² copper-wire screen, XLPE insulated. 5 km circuit length.
Substation Y earth resistance	0.1 Ω
Substation X earth resistance	0.5 Ω
Reduction factor for cable between Substations X and Z	$0.067\angle 178^\circ$ (From Table 12)

Table 12 — Calculated ground return current

Contribution From:	$3I_0$ magnitude (kA)	$3I_0$ angle (deg)	r_E Magnitude	r_E angle (deg)	I_{ES}/I_E magnitude (kA)	I_{ES}/I_E angle (deg)
Substation Y	2.916	76.9	0.708	-9	2.06	67.9
Substation Z	8.559	74.8	0.067	178	0.565	252.8
Sum of Contributions from Substations Y+Z	11.470	75.3			1.50	66.1

6.4.5 Earth potential rise (EPR)

The EPR can be calculated simply as the product of the ground return current I_E and the overall earth resistance R_E at Substation X, i.e. $1.5 \text{ kA} \times 0.5 \Omega = 750 \text{ V}$

6.5 Case study 5: 11 kV substation and LV earthing interface

A 500 kVA 11 kV unit substation is looped into two 11 kV, 185 mm² aluminium triplex cables with 35 mm² copper screens, each 1 km long. Cable self and mutual impedances are taken from Table D.2. One cable is connected to the 11 kV source and the other is feeding an open 11 kV ring. A cladding enclosure surrounds the substation and a concrete raft covers the internal area of approximately 3x3 m. The soil resistivity is 50 Ω·m and the maximum fault current for a single phase to earth fault is 3 kA. A fault clearance time of 1 s is assumed and the corresponding permissible touch voltage (on soil) is 233 V. In this example, polymeric LV cables are assumed to be employed which offer no effective contribution to earthing.

6.5.1 Design option 1

This preliminary design assumes an earth electrode comprising a perimeter horizontal bare copper electrode (size 25 mm x 4 mm) around the plinth buried at a depth of 0.6 m with four vertical rod electrodes connected at each corner. The rods are assumed to be 2.4 m long and 16 mm diameter.

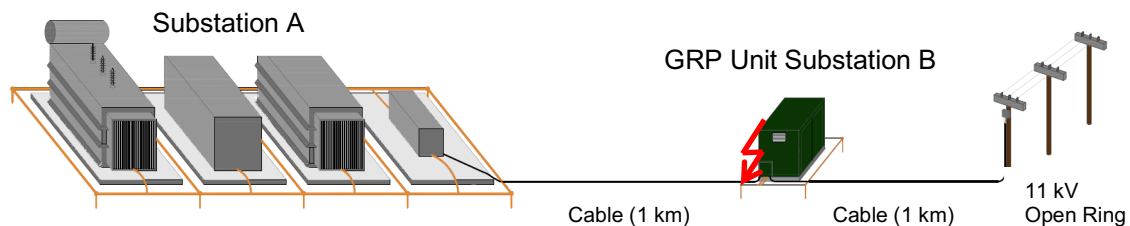

Figure 13 — Case study 5: Option 1

Using formulae R4 to R6:

$$R_1 = R_{ES} = \frac{\rho}{4r} + \frac{\rho}{L_E}$$

L_E = length of horizontal electrode

$$R_R = \frac{\rho}{2\pi L_R} \left(\log_e \frac{8L_R}{d} - 1 \right)$$

L_R = rod length

d = diameter. Valid for $d \ll L_R$

$$R_2 = R_{ER} = R_R \left(\frac{1 + k\alpha}{N} \right)$$

$$r = \sqrt{\frac{A}{\pi}}$$

$$\alpha = \frac{\rho}{2\pi R_R S}$$

N = total number of rods = 4; k and α defined below.

$$R_{12} = R_1 - \frac{\rho}{\pi L_E} \left(\log_e \frac{L_R}{b} - 1 \right)$$

$$R_E = \frac{R_1 R_2 - R_{12}^2}{R_1 + R_2 - 2R_{12}}$$

A = area of grid (m²)

s is the distance between rods (m)

Therefore:

2.4 m rod length, 16 mm diameter.

$$R_1 = \frac{50}{4 \times 1.69} + \frac{50}{12} = 11.56 \Omega$$

$k = 2.6$ for 4 rods (From Figure B.1)

$$R_R = \frac{50}{2\pi \times 2.4} (\log_e \left(\frac{8 \times 2.4}{0.016} \right) - 1) = 20.19 \Omega$$

$$\alpha = \frac{50}{2\pi \times 20.19 \times 3} = 0.13$$

$$R_2 = 20.19 \times \left(\frac{1 + 2.6 \times 0.13}{4} \right) = 6.75 \Omega$$

$$R_{12} = 11.56 - \frac{50}{\pi \times 12} \left(\log_e \frac{2.4}{0.01} - 1 \right) = 5.62 \Omega$$

$$R_E = \frac{11.56 \times 6.75 - 5.62^2}{11.56 + 6.75 - 2 \times 5.62} = 6.57 \Omega$$

As this is a preliminary design, several conservative assumptions can be made. The source resistance is assumed to be 0.1 Ω and the attenuation of fault current by the earth resistance and circuit impedance is neglected at this stage.

6.5.2 C-factor method

This arrangement (all cable circuit) is shown in Figure D.1.

$$I_E = I_F \times \frac{\frac{C}{(a + 9E)}}{\sqrt{\left\{ \left(\frac{C}{a + 9E} + \frac{R_{AB}}{\ell} \right)^2 + 0.6 \left(\frac{\rho}{aE} \right)^{0.1} \right\}}}$$

Table 13 —Option 1 input data and results

Parameter	Value
E	11 kV
ρ	50 $\Omega \cdot m$
a	185 mm ²
C	47 (from Table D.2)
R_A	0.1 Ω
R_B	6.57 Ω
$R_{AB} = R_A + R_B$	6.67 Ω
ℓ	1 km
I_F	3000 A
$I_E \%$	2.41 %
I_E	72.3A
EPR_B	475 V

6.5.3 Matrix method

This method is appropriate where cable physical parameters are available. Self and mutual impedance values can be determined from data provided by manufacturers (or from measurements) and by using formulae in Appendix D.

The fault current distribution and calculated EPR associated with the source 11 kV cable, calculated for option 1 using the formulae in Appendix D is shown in Table 14.

Table 14 — Resultant fault current distribution and EPR (matrix method)

Parameter	Value
$I_E \%$	2.41 %
I_E	72.3 A
EPR_B	475 V

6.5.4 Results

It can be seen that both methods give identical results. The EPR exceeds $2 \times U_{TP}$ ($2 \times 233 \text{ V} = 466 \text{ V}$) and therefore segregation of HV/LV earthing systems is required.

6.5.5 Surface current density

The surface current density of the earth electrode for the fault conditions listed above should be evaluated and compared with the limit of surface current density, provided by Formula C2 as shown below:

$$J_{\text{limit}} = 10^{-3} \left(\frac{57.7}{\rho t} \right)^{1/2}$$

i.e.:

$$J_{\text{limit}} = 10^{-3} \left(\frac{57.7}{50 \times 3} \right)^{1/2} = 0.62 \times 10^{-3} \text{ A/mm}^2 \quad (t = 3 \text{ s})$$

The total electrode surface area is:

$$\begin{aligned} \text{Horizontal electrode surface area} &= 696 \times 10^3 \text{ mm}^2 \\ \text{Vertical rod surface area} &= 483 \times 10^3 \text{ mm}^2 \\ \text{Total electrode surface area} &= 1180 \times 10^3 \text{ mm}^2 \end{aligned}$$

Assuming a uniform current distribution throughout the earthing system, the actual current density is:

$$J = \left(\frac{72.3}{1180 \times 10^3} \right) = 61.3 \times 10^{-6} \text{ A/mm}^2$$

Based on the above, the actual current density is below the limit of surface current density, hence the amount of electrode installed is adequate. The electrode will remain within limits for a total ground return current up to 731 A. The impact of this limit should be considered for future planning i.e. increased fault levels or loss of sheath connection.

6.5.6 Design option 2

A second design is considered and comprises the arrangement described in option 1 together with a bare stranded electrode buried with each 11 kV cable for a distance of 20 m and connected to the substation earthing system.

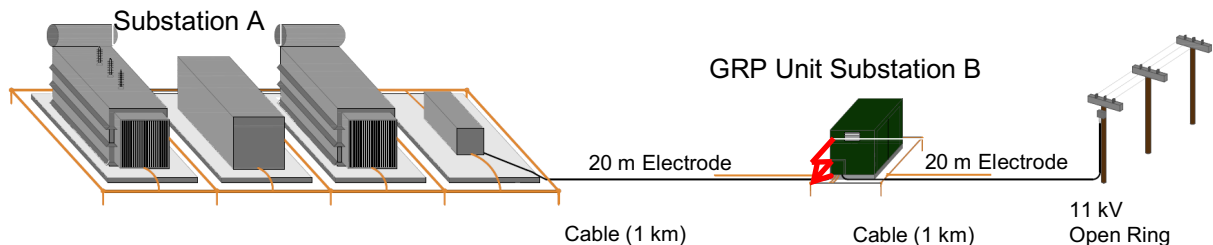

Figure 14 — Case study 5: Option 2

The resistance of each extended horizontal electrode can be calculated using Formula R7:

$$R_H = \frac{\rho}{2\pi L_H} \left[\log_e \left(\frac{2L_H}{d} \right) \right]$$

$$R_{EH} = \frac{50}{2\pi \times 20} \left[\log_e \left(\frac{2 \times 20}{0.00944} \right) \right] = 3.3 \Omega.$$

Ignoring proximity effects, the combined parallel resistance for the substation and both horizontal electrodes is 1.33 Ω. Using the same basic assumptions as Section 6.5.1, the fault current distribution and EPR for the earthing arrangement, calculated using the two methods provided in Appendix D, is given in Table 15 and Table 16.

6.5.7 C-factor method

This arrangement (all cable circuit) is given in Figure D.1.

$$I_E = I_F \times \frac{\frac{C}{(a + 9E)}}{\sqrt{\left\{ \left(\frac{C}{a + 9E} + \frac{R_{AB}}{\ell} \right)^2 + 0.6 \left(\frac{\rho}{aE} \right)^{0.1} \right\}}}$$

Table 15 — Option 2 input data and results

Parameter	Value
E	11 kV
ρ	50 $\Omega \cdot m$
a	185 mm ²
C	47 (from Table D.2)
R_A	0.1 Ω
R_B	1.33 Ω
$R_{AB} = R_A + R_B$	1.43 Ω
ℓ	1 km
I_F	3000 A
$I_E \%$	9.62 %
I_E	278 A
EPR_B	361 V

6.5.8 Matrix method

This method is appropriate where cable physical parameters are available. Self and mutual impedance values can be determined from data provided by manufacturers (or from measurements) and by using formulae in Appendix D.

The fault current distribution and calculated EPR associated with the source 11 kV cable calculated for option 2 using the formulae in Appendix D is given in Table 16.

Table 16 — Resultant fault current distribution and EPR (matrix method)

Parameter	Value
$I_E \%$	8.27 %
I_E	248 A
EPR_B	394 V

6.5.9 Results

Table 15 and Table 16 demonstrate that the EPR based on the second preliminary design is below the 466 V permissible touch voltage and therefore a combined HV/LV earthing system can be installed.

APPENDICES

- A Symbols used within formulae or figures
- B Formulae
- C Earthing design methodology (block diagram)
- D Formulae for determination of ground return current for earth faults on metal sheathed cables
- E Ground current for earth faults on steel tower supported circuits with aerial earth wire
- F Chart to calculate resistance of horizontal electrode
- G Chain impedance of standard 132 kV earthed tower lines
- H Sample calculations showing the effect on the ground return current for change in the separation between three single-core cables
- I Transfer potential from HV systems to LV systems with multiple earthed neutral

Appendix A Symbols used within formulae or figures

(Those shown in **Old** column were used in earlier versions of this document, but have been updated to align as far as possible with BS EN 50522:2010).

New	Old	Symbol Description
a		Conductor cross-sectional area (mm ²)
b	b	equivalent diameter of circular electrode (m)
C		'C' factor used to calculate split of current between ground and metallic return paths (cable sheaths)
CH	CH	chain (or ladder) network of an overhead line earth wire with its connections to earth via metal lattice towers along its route, or an insulated cable's sheath that has connections to earth via installations along its length
d	d	diameter of circular electrode (or width of tape electrode) (m)
D	D	average spacing between parallel grid electrodes (m)
E		System voltage (kV)
h	h	radius of equivalent hemisphere (m)
I_E	I_{gr}	component of I_F that flows through the electrode network and eventually all returning through the ground (A)
I_{ES}	I_E	component of I_F passing to ground through grid electrode (A)
I_{ET}	I_t	component of I_E passing to ground through tower footing (A)
I_F	I_F	total earth fault current (A)
I_h	I_h	component of I_E passing to ground through external horizontal electrode (A)
I_N	I_l	current via local transformer neutral (A)
I_r	I_r	component of I_F through remote transformer neutrals (A)
I_S	I_{Sr}	component of I_F returning through earth wire or cable sheath (A)
J_{limit}		Limiting current density (A/mm ² of electrode surface area)
k	k	geometric coupling factor or arrangement factor
ℓ	l or L_C	cable length (km)
L_E	L or l_E	total length of electrode (e.g. in grid, not including rods) (m)
L_H	l_H	horizontal electrode length (m)

New	Old	Symbol Description
L_P	l_P	grid or loop electrode length (perimeter) (m)
L_R	l_R	length of earth rod (m)
L_T		total electrode length, including horizontal electrode and summated rod lengths (m)
r_E	r_E	reduction factor of the overhead line
ρ	ρ	earth resistivity ($\Omega \cdot m$)
r_a	r_a	cable armour resistance per unit length (Ω/km)
R_A		earthing resistance at substation A (Ω)
R_B		earthing resistance at substation B (Ω)
r_c	r_c	cable sheath resistance per unit length (Ω/km)
R_E	R_e	total earthing resistance at substation (Ω) [or resistance of specific electrode]
R_{EH}	R_h	external horizontal electrode earthing resistance (Ω)
R_{EP}	R_p	earth plate resistance (Ω)
R_{ER}	R_2	resistance of group of rods (Ω)
R_{ES}	R_i and R_g	grid electrode earthing resistance (Ω)
R_{ET}	R_t	tower footing resistance (Ω)
R_f	R_f	fault resistance (Ω)
R_{NE}	R_{ne}	neutral earthing resistance (Ω)
R_R		resistance of single rod (Ω)
s	S	line span length (km)
U_E	V_e	rise of earth potential of substation (V)
U_S		step potential (V)
U_{SP}		permissible step potential (V)
U_T		touch potential (V)
U_{VS}		prospective step potential (V)

New	Old	Symbol Description
U_{VT}		prospective touch potential (V)
U_{TP}		permissible touch voltage (V)
φ		Phase angle (degrees or radians)
V_x	V_s	voltage on the surface of the soil at point S (point x), with respect to true earth potential (V)
V_T		transfer potential (V)
x		distance to point where voltage on soil is V_x (m)
Z_C	z_c	(cable sheath impedance) - the impedance of the overall sheath and armour of 3-core cables, or of all three sheaths of 3 × single-core cables, per unit length (Ω/km)
Z_{CH}	Z_{ch}	chain (or ladder) network impedance (Ω) (Referred to as Z_p in BS EN 60909-3; referred to as Z_∞ in BS EN 50522:2010)
Z_E	Z_e	impedance to earth, substation earthing impedance (Ω)
$Z_{mp,1}$	$Z_{mp,1}$)
$Z_{mp,2}$	$Z_{mp,2}$	mutual impedance between cable conductor and sheaths 1, 2 and 3 respectively of three single-core cables (Ω/km)
$Z_{mp,3}$	$Z_{mp,3}$)
$Z_{ml,2}$	$Z_{mp,2}$)
$Z_{ml,3}$	$Z_{mp,3}$	mutual impedance between sheaths 1, 2 and 3 of three single-core cables (Ω/km)
$Z_{m2,3}$	$Z_{mp,3}$)
$Z_{mp,s}$	$Z_{mp,s}$	mutual impedance between line conductor and earth wire (Ω/km)
$Z_{mp,c}$	$Z_{mp,c}$	mutual impedance between cable conductor and sheath of three-core cables (Ω/km)
Z_Q		tower line earth wire impedance per unit length (Ω/km)
z_S		earth wire impedance per unit length (Ω/km)
\angle	\angle	angle in degrees

Appendix B Formulae

Symbols are as given in Appendix A unless otherwise re-defined in this Appendix.

Formulae in this section are those which are considered most relevant to UK network operators. They may differ from those in BS EN 50522 where they are known to be a simplification and/or restricted in their application.

See BS 7430 for additional formulae related to simple rod arrangements that would not generally be used at distribution or transmission network operator installations.

The formulae have been grouped as follows:

R = earth resistance of different arrangements.

C = current rating.

P = potentials (surface, touch and step).

B.1 Earth resistance formulae (R)

B.1.1 Formula R0: Hemispherical electrode

$$R_E = \frac{\rho}{2\pi r} \quad \text{where: } r = \text{radius of hemisphere (m)}$$

B.1.2 Formula R1: Rod electrode

$$R_R = \frac{\rho}{2\pi L_R} \left[\log_e \left(\frac{8L_R}{d} \right) - 1 \right] \quad \text{valid for } L_R \gg d/2$$

B.1.3 Formula R2: Plate electrode (mainly used for sheet steel foundations)

$$R_{EP} = \frac{\rho}{8r} \left(1 + \frac{r}{2.5h + r} \right) \quad \text{where: } r = \sqrt{\frac{A}{\pi}}$$

A = area of one face of the plate (m²)
 h = depth of burial (m)

B.1.4 Formula R3: Ring electrode

$$R_E = \frac{\rho}{4\pi^2 r} \left(\log_e \frac{64r^2}{dh} \right) \quad \text{where: } h = \text{depth (m)}$$

r = ring radius (m) = $\sqrt{\frac{A}{\pi}}$
 d = conductor diameter (m)

B.1.5 Formula R4: Grid/mesh resistance

$$R_{ES} = \frac{\rho}{4r} + \frac{\rho}{L_E}$$

where:

$$r = \sqrt{\frac{A}{\pi}}$$

A = area of grid (m²)

L_E = total length of buried conductor excluding rods (m)

B.1.6 Formula R5: Group of rods around periphery of grid

$$R_{ER} = R_R \left(\frac{1 + k\alpha}{N} \right)$$

where: R_R = Resistance of one rod (Ω) (Formula R1)

$$\alpha = \frac{\rho}{2\pi R_R s}$$

s = spacing of rods (m)

N = total number of rods around periphery of grid

k = factor from Figure B.1 below.

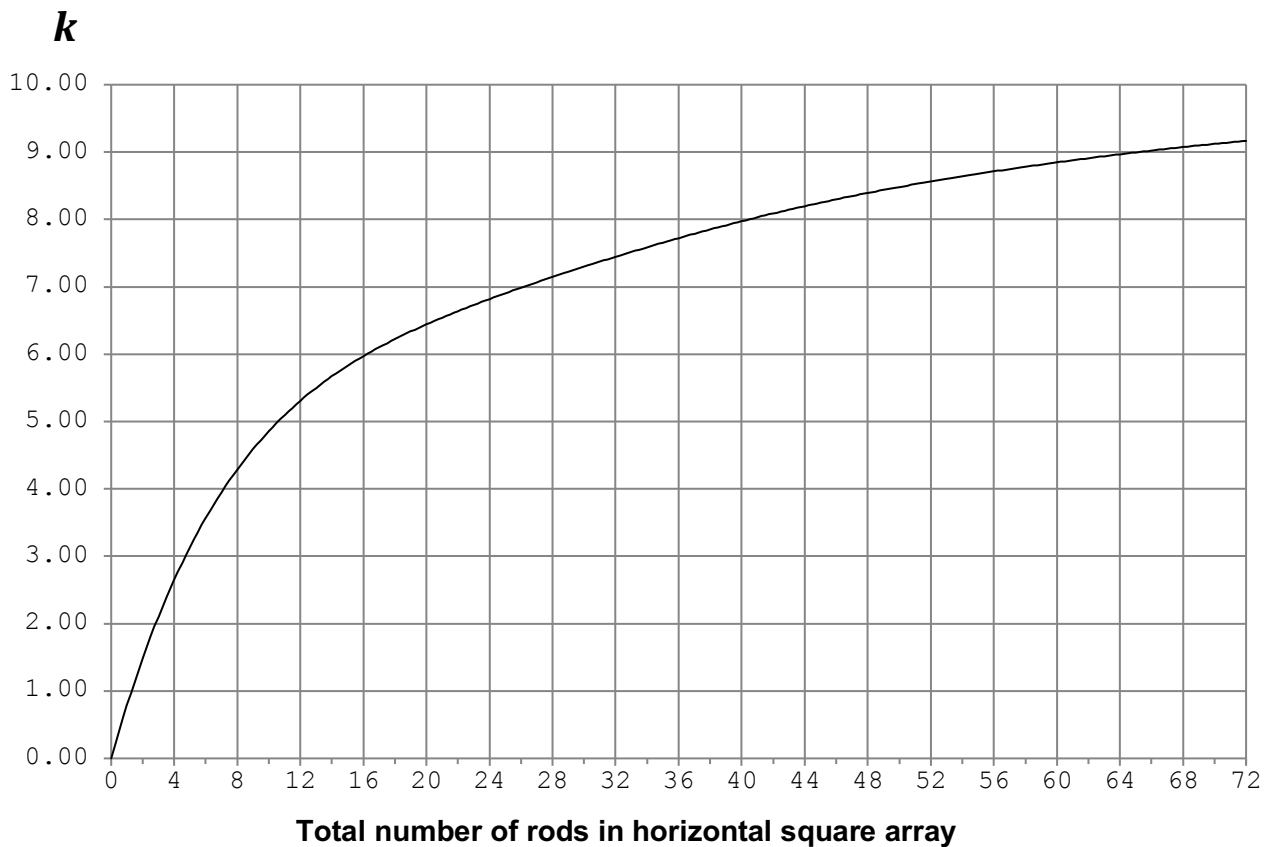

Figure B.1 — Factor *k* for formula R5

B.1.7 Formula R6: Combined grid and rods (rods on outside only)

$$R_E = \frac{R_1 R_2 - R_{12}^2}{R_1 + R_2 - 2R_{12}}$$

where: $R_1 = R_{ES}$ = resistance of grid (Formula R4)

$R_2 = R_{ER}$ = resistance of group of rods around periphery of grid (Formula R5)

$$R_{12} = R_1 - \frac{\rho}{\pi L_E} \left(\log_e \frac{L_R}{b} - 1 \right)$$

$$b = w/\pi$$

where:

w = width of tape electrode (m)

L_E = length of buried conductor excluding rods (m)

L_R = rod length (m)

NOTE: The formula gives sensible results only for generally used dimensions – in particular for normal rod widths/diameters and spacing.

B.1.8 Formula R7: Strip/tape electrode

For horizontal electrodes, the following formula (from BS EN 50522) may be used:

$$R_H = \frac{\rho}{2\pi L_H} \left[\log_e \left(\frac{2L_H}{d} \right) \right]$$

where: depth of burial = 0.5 to 0.6 m

d = diameter of round conductor or half-width of tape (m)

The above formula is valid for $L_H \gg d$ and $L_H \leq 60\sqrt{\rho}$ (see Table B.1).

With increasing electrode length, there will be a point after which the effect of adding further length is significantly diminished due to the self-impedance of the electrode that is not accounted for. These lengths for a single earth wire, tape or PILCSWA cable are shown in Table B.1. The behaviour with length of the resistance of long horizontal conductors R_{EH} is illustrated by the typical values shown in Figure F.1.

Table B.1 - Approximate lengths for a single horizontal earth wire, tape or PILCSWA cable beyond which no further significant reduction in resistance can be obtained

Soil resistivity ρ ($\Omega \cdot m$)	Length L_H (m) $= 60\sqrt{\rho}$
1	60
10	190
100	600
1000	1900

In cases where there are several conductors in reasonably close proximity, computer software or a more detailed formula (such as Schwarz [4]) should be used. The advantage of using computer software is that the extended electrode cross sectional area and material can be correctly accounted for.

B.1.9 Formula R8: Ladder networks

NOTE: In Formulae R8.1 and R8.2 below, quantities are complex impedances, rather than magnitudes. For triplex cables, or single-core cables, the combined sheath resistance will be the parallel value, but the reactance should be calculated for the dimensions/spacing for them to act as an equivalent single sheath conductor. For circuits feeding the fault, mutual coupling between the faulted phase conductor and the sheath(s) etc. also plays a significant role. In many circumstances calculating these effects will not be practicable; the formulae should therefore be used only to provide an approximation in such circumstances. More accuracy can be achieved by the use of appropriately modelled sheath impedance data (e.g. provided by manufacturer), or by using a computer program that is able to calculate the parameters from the physical properties of each cable section.

Formula R8.1: Long overhead lines with earth wire (BS EN 60909-3, 2010)

$$Z_{CH} = 0.5Z_Q + \sqrt{(0.5Z_Q)^2 + R_{ET} \cdot Z_Q} \quad \text{where: See BS EN 60909-3 for description of } Z_Q.$$

NOTE: Appendix G gives calculated values of Z_{CH} for a traditional UK 132 kV tower line.

Formula R8.2: Long cable circuit with distributed earthed nodes (distribution substation electrodes) (BS EN 60909-3)

$$Z_{CH} = \frac{Z_1 + \sqrt{Z_1^2 + 4 \cdot Z_1 \cdot Z_2}}{2} \quad \text{where: } Z_1 = \text{equivalent longitudinal sheath impedance of cable connecting the substations. For single-core or triplex cables, this should take into account spacing/geometry between single-core cables.}$$

$Z_2 = \text{average substation earthing impedance}$
 $(0j + R_B) \Omega$

Formula R8.3: Short overhead lines with earth wire (typically 5 to 20 towers)

$$Z_{CH} = \frac{Z_P(Z_{EB} + Z_P)k^n + (Z_P - Z_Q)(Z_{EB} - Z_P + Z_Q)k^{-n}}{(Z_{EB} + Z_P)k^n - (Z_{EB} - Z_P + Z_Q)k^{-n}}$$

NOTE 1: All impedances are in complex notation. Formula as provided in (BS EN 60909-3).

NOTE 2: Refer to BS EN 60909-3 for descriptions of symbols, as they differ from those used in this document.

For detailed calculations, a discrete ladder network (iterative) routine or computer software should be used. The self and mutual impedance for the earth wire(s) should be calculated accounting for their material, cross sectional area and the circuit geometry.

Short underground cable/substation arrangements

Where a significant proportion of the cable is PILCSWA, the resistance is calculated based entirely on this, using Formula R7.

Where the majority of the cable is XLPE/EPR/Triplex etc., an approximate approach is to treat all the substation earth resistances as being in parallel and inflate the result by 30 % to account for the longitudinal sheath impedance. This is sufficiently accurate for typical cable lengths of 200 m to 450 m and low sheath impedance. If more than 6 substations are to be considered, a higher inflation amount needs to be considered. Detailed calculations will be needed if the substation earth resistances approach 1 Ω or less, because the sheath impedance then becomes significant.

For detailed calculations, a discrete ladder network (iterative) routine or computer software should be used.

See also BS EN 60909-3 for more details of the calculations for ladder networks, including non-symmetrical arrangements.

B.1.10 Formula R9: Accounting for proximity effects

The resistance R_t (Ω) of n vertically driven rods set s metres apart may be calculated from:

$$R_t = \frac{1}{n} \frac{\rho}{2\pi L_R} \left[\log_e \left(\frac{8L_R}{d} \right) - 1 + \frac{\lambda L_R}{s} \right]$$

where: ρ = is the resistivity of soil, in ohm metres ($\Omega \cdot m$)
 L_R = is the length of the electrode, in metres (m);
 n = is the number of rods;
 s = is the spacing between rods
 λ = a group factor where: $\lambda = 2 \sum \left(\frac{1}{2} + \dots + \frac{1}{n} \right)$

NOTE: For larger values of n , λ can be approximated by: $\lambda \simeq 2 \log_e \frac{1.781n}{2.818}$ See Bibliography, reference [3].

B.1.11 Formula R10: Overall earth resistance

$$Z_E = \left(\frac{1}{R_{ES}} + \frac{1}{Z_{CH1}} + \frac{1}{Z_{CH2}} + \dots \right)^{-1}$$

NOTE: The overall impedance of an earthing system can be approximated to the parallel combination of all component parts. This formula neglects proximity effects (overlapping resistance areas) and will generally provide a lower value for Z_E than might be observed in practice (or provided by simulation results).

Computer software is best used to account for proximity effects e.g. where strip electrodes or PILCSWA type cables run in parallel.

B.2 Current formulae

B.2.1 Formula C1: Current rating formula

For fault currents which are interrupted in less than 5 s the cross-section of earthing conductor or earth electrode shall be calculated from the following formula:

$$A = \frac{I}{K} \sqrt{\frac{t_f}{\log_e \left(\frac{\theta_f + \beta}{\theta_i + \beta} \right)}}$$

where: A = cross-section (mm^2)
 I = conductor current (A) (RMS value)
 t_f = duration of the fault (s)
 K = a constant depending on the material of the current-carrying component; Table D.1 of IEC 60949 provides values for the most common materials assuming an initial temperature of 20 °C
 β = reciprocal of the temperature coefficient of resistance of the current-carrying component at 0 °C.
 θ_i = initial temperature in degrees Celsius. Values may be taken from (IEC 60287-3-1). If no value is laid down in the national tables, 20 °C as ambient

ground temperature at a depth of 1 m should be adopted.

θ_f = final temperature (°C)

(See IEC 60949, formula D1)

NOTE: Care should be taken not to exceed safe temperatures for cable sheaths (and their insulation), particularly on heavily loaded circuits where the initial temperature may be close to 90 °C.

B.2.2 Formula C2: Limit of surface current density formula

Actual current density:

$$\text{Surface Current Density} = \frac{\text{Electrode Current}}{\text{Surface Area of Electrode}} \text{ (A/mm}^2\text{)}$$

Limiting current density:

$$J_{\text{limit}} = 10^{-3} \left(\frac{57.7}{\rho t} \right)^{1/2} \text{ (A/mm}^2\text{)} \quad \text{where: } \rho = \text{soil resistivity } (\Omega \cdot \text{m})$$

$$t = \text{fault duration (s)}$$

B.3 Surface potential formulae (P)

For substations with separately earthed fence and normal buried grid depths (typically 0.5 m):

B.3.1 Formula P1: External touch potential at the edge of the electrode

$$U_T = \frac{k_e \cdot k_d \cdot \rho \cdot I_E}{L_T} \text{ (V)} \quad \text{where: } k_e = \text{factor that allows for the effect of a uniformly distributed electrode current over the grid (see below)}$$

$$k_d = \text{factor, which modifies } k_e \text{ to allow for the non-uniform distribution of electrode current (see below)}$$

$$\rho = \text{soil resistivity } (\Omega \text{ m})$$

$$I_E = \text{total current passing to ground through electrode (A)}$$

$$L_T = \text{total length of buried electrode conductor including rods if connected (m)}$$

$$k_e = \frac{1}{\pi} \left(\frac{1}{2} \log_e \frac{h}{d} + \frac{1}{2h} + \frac{1}{(0.5 + D)} + \frac{1}{D} (1 - 0.5^{n-2}) \right)$$

h = grid depth (m)

d = equivalent diameter of conductor = $\frac{\text{circumference of conductor}}{\pi}$ (m)

D = average spacing between parallel grid conductors (m)

$$n = (n_A \times n_B)^{1/2}$$

where n_A = number of parallel grid conductors in one direction

where n_B = number of parallel grid conductors in the other direction

$$k_d = \left(0.7 + 0.3 \frac{L_T}{L_p} \right)$$

where:

L_T = total length of buried electrode conductor including rods if connected (m)

L_p = perimeter length of buried electrode conductor including rods if connected (m)

U_T = resulting touch potential or, when assessing length L , the permissible touch potential from ENA TS 41-24, Table 1

B.3.2 Formula P2: External touch potential at the fence

The ground current density is significantly diminished at the fence compared to that at the edge of the grid electrode. As a result, a new factor, k_f , based on a 2 m separation between fence and grid electrode, is applied in place of k_e in the above formulae.

Hence:

$$U_{T(\text{fence})} = \frac{k_f \cdot k_d \cdot \rho \cdot I_{ES}}{L_p} \quad (\text{V})$$

Or, rearranged:

$$L_p = \frac{k_f \cdot k_d \cdot \rho \cdot I_{ES}}{U_T} \quad (\text{m}) \quad \text{where: } k_f = 0.26k_e \quad (\text{based on 2 m separation})$$

There are two situations to be considered. The first is where the fence is situated at the edge of the substation electrode. The second has a peripheral electrode conductor buried 0.5 m below the surface, 1 m beyond the fence and regularly bonded to it:

B.3.3 External touch potential at fence with no external peripheral electrode:

$U_{T(\text{fence})}$ is the same as $U_{T(\text{grid})}$ using formula P1 as above.

B.3.4 Formula P3: External touch potential at fence with external buried peripheral conductor 1 m from fence

$$U_{T(\text{fence})} = \frac{k_{fe} \cdot k_d \cdot \rho \cdot I_{ES}}{L_p} \quad (\text{V}) \quad \text{or} \quad L_p = \frac{k_{fe} \cdot k_d \cdot \rho \cdot I_{ES}}{U_{T(\text{fence})}} \quad (\text{m})$$

Where:

$$k_{fe} = \left(\frac{1}{2} \log_e \frac{h}{d} - \frac{1}{4} \log_e (S^2 + 0.5^2)^2 + \frac{1}{4} \log_e (S^4 + S^2) \right)$$

h and d are as in formula P1;

S = distance between the outermost buried grid conductor and the next nearest parallel conductor (m).

B.3.5 Formula P4: Touch potential within grid (from IEEE 80)

The touch potential within the earth grid may be calculated using the following formulae from IEEE 80, Annex D, where it is defined as the mesh voltage. It is the touch potential that would be experienced at the centre of a corner mesh in an earth grid with an equally spaced mesh.

NOTE: Terms used in these formulae are not defined in the rest of this document, and are included here for consistency with the source document (IEEE 80).

$$E_m = \frac{\rho \times I_{ES} \times K_m \times K_i}{L_C + \left[1.55 + 1.22 \times \left(\frac{L_r}{\sqrt{L_x^2 + L_y^2}} \right) \right] \times L_R}$$

$$K_m = \frac{1}{2 \times \pi} \times \left[\ln \left[\frac{D^2}{16 \times h \times d} + \frac{(D + 2 \times h)^2}{8 \times D \times d} - \frac{h}{4 \times d} \right] + \frac{K_{ii}}{K_h} \times \ln \left[\frac{8}{\pi(2 \times n - 1)} \right] \right]$$

$$K_i = 0.644 + 0.148 \times n$$

$$n = n_a \times n_b \times n_c \times n_d$$

$$n_a = \frac{2 \times L_C}{L_p}$$

$$n_b = 1 \text{ for square grids, otherwise: } n_b = \sqrt{\frac{L_p}{4 \times \sqrt{A}}}$$

$$n_c = 1 \text{ for square and rectangular grids, otherwise: } n_c = \left[\frac{L_x \times L_y}{A} \right]^{\frac{0.7 \times A}{L_x \times L_y}}$$

$$n_d = 1 \text{ for square, rectangular and L-shaped grids, otherwise: } n_d = \frac{D_m}{\sqrt{L_x^2 + L_y^2}}$$

$$K_h = \sqrt{1 + \frac{h}{h_0}}$$

$$K_{ii} = 1 \quad (\text{for grids with numerous earth rods, especially where they are located at the corners and around the perimeter})$$

$$K_{ii} = \frac{1}{(2 \times n)^{\frac{2}{n}}} \quad (\text{for grids with no (or very few) earth rods, especially where they are not located on corners or around the perimeter})$$

where:

E_m = the mesh voltage (V)

ρ = the average soil resistivity ($\Omega \cdot m$)

I_{ES} = electrode current (A)

L_C = total length of horizontal conductor in the grid (m)

L_R = total length of all earth rods (m)

- L_r = average earth rod length (m)
- L_p = length of the perimeter conductor (m)
- L_x = maximum length of the grid in the x direction (m)
- L_y = maximum length of the grid in the y direction (m)
- D = spacing between parallel conductors in the mesh (m)
- d = diameter of the earth conductors (m)
- h = grid burial depth (m)
- A = area of the grid (m²)
- D_m = maximum distance between any two points on the grid (m)
- h_0 = grid reference depth of 1 m

B.3.6 Formula P5: Step potential on outside edge of grid

$$U_S = \frac{\rho I_F}{2\pi r} \left(\arcsin \frac{r}{x} - \arcsin \frac{r}{x+1} \right) \quad \text{where: } r = \frac{\rho}{4R_{ES}}$$

x = distance from centre of grid

B.3.7 Formula P6: Voltage profile around earth electrode

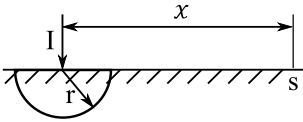
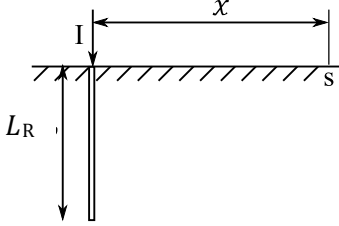
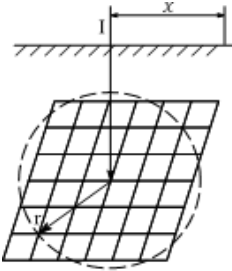
Column	P6.1	P6.2	P6.3
Electrode description	Hemisphere	Vertical rod	Buried grid
Configuration, where I = injected current.			
Voltage V_x with respect to true earth on the surface of the ground at distance x	<p>for $x > r$</p> $V_x = \frac{\rho \cdot I}{2\pi x}$ $= U_E \left(\frac{r}{x} \right)$	<p>for $x > d/2$</p> $V_x = \frac{\rho \cdot I}{2\pi L_R} \log_e \left(\frac{L_R}{x} + \sqrt{1 + \frac{L_R^2}{x^2}} \right)$ $= U_E \frac{\rho}{2\pi L_R R_R} \log_e \left(\frac{L_R}{x} + \sqrt{1 + \frac{L_R^2}{x^2}} \right)$	<p>for $x > r$</p> $V_x = \frac{\rho \cdot I}{2\pi r} \arcsin \frac{r}{x}$ $= \frac{2U_E}{\pi} \arcsin \frac{r}{x}$ <p>where: $r = \frac{\rho}{4R_{ES}}$ and $\arcsin \frac{r}{x}$ is in radians</p>

B.3.8 Formula P7: Calculation of specific external potential contours

$$x = \sqrt{\frac{A}{\pi}} \left[\left(\sin \frac{V_x \pi}{2U_E} \right)^{-1} - 1 \right]$$

where: x = distance (m) from edge of grid (effective radius r) to a point where the surface potential is V_x (V)
 $A = \pi r^2$ (m²), where $r = \frac{\rho}{4R_{ES}}$ (see Formula P.6.3)
 U_E = earth potential rise (V)

NOTE: Angles are in radians.

These formulae apply on the basis that the earthing installation may be treated as equivalent to a symmetrical grid.

Substation fences are usually earthed independently from the main earthing system and may be up to 2 m from it. By using the above formulae to calculate the radius of any voltage contour, a factor of safety is introduced when they are measured from the substation fence. Some discretion may be necessary in assessing the radius from a substation where the fence is bonded to the earthing installation or there is a large distance from the fence to the edge of the earthing system.

Clearly, this formula does not apply when U_E is lower than the voltage contour of interest.

Appendix D Formulae for determination of ground return current for earth faults on metal sheathed cables

D.1 Introduction

The current in the core of a single-core cable or the unbalance of current in the cores of a multicore cable induces a voltage in the metallic sheath/armour of the cable. If the sheath/armour is connected to earth at each end of its length, a current will be driven through the sheath/armour earth loop which constitutes part of the earth fault current returning from the fault, the remainder being that returning in the ground. The quantity of current returning in the cable sheath/armour is, inter alia, dependent on the location of the cable in the system with respect to the source of fault current infeed and to the position of the fault as well as on the values of the sheath/armour terminating earth resistances.

Formulae for the computation of the ground current are given below, in respect of a cable sheath terminated and earthed at points A and B. These are based upon circuit models including the self and mutual impedances between the different physical conductors (cores, sheaths, screens). The arrangements considered are illustrated in Figures D.1 to D.4.

Alternative formulae are provided in Section D.4 based on empirical methods and include a 'coupling factor', C , a constant that reflects the physical construction of the sheath.

Tables D.1 and D.2 give self and mutual impedances together with the associated C -factors, for three-core and single-core cables typically used on the UK distribution network. Where a cable is not available on the list the nearest cable with a smaller core cross-sectional area will normally provide a conservative calculation of ground return current. Self and mutual impedances for non-standard cables should be derived from first principles.

NOTE: Refer to Appendix A for explanation of symbols not included in Figures.

D.2 Circuit arrangements

D.2.1 Cable circuit, local source, fault at cable end

This arrangement is illustrated in Figure D.1.

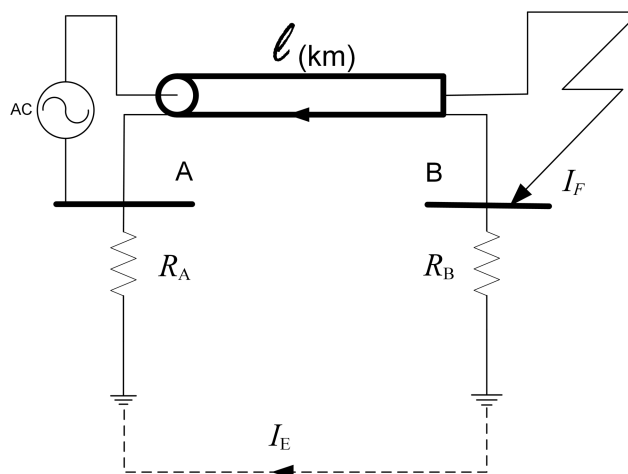

Figure D.1 — Cable circuit, local source, fault at cable end

The following formulae may be used to calculate the ground return current (I_E) for the arrangement shown in Figure D.1 for armoured and unarmoured 3-core cables.

Unarmoured cable:

$$I_E = -I_F \left[\frac{\ell(z_c - z_{mp,c})}{\ell z_c + R_A + R_B} \right] = -I_F \left[\frac{\ell r_c}{\ell z_c + R_A + R_B} \right]$$

Armoured cable:

$$I_E = -I_F \left[\frac{\ell \left(\frac{r_c \times r_a}{r_c + r_a} \right)}{\ell \left(\frac{r_c \times r_a}{r_c + r_a} \right) + r_c + j\omega(L_c + L_a) + R_A + R_B} \right]$$

D.2.2 Cable-line circuit, local source, remote fault

This arrangement is illustrated in Figure D.2.

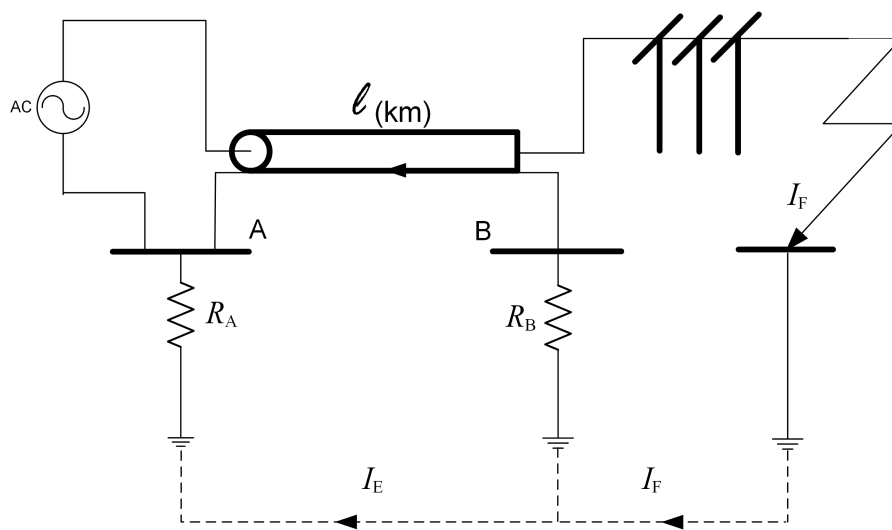

Figure D.2 — Cable-line circuit, local source, remote fault

The following formulae may be used to calculate the ground return current (I_E) for the arrangement shown in Figure D.2 for 3-core armoured and unarmoured cables.

Unarmoured Cable:

$$I_E = -I_F \left[\frac{\ell(z_c - z_{mp,c}) + R_B}{\ell z_c + R_A + R_B} \right] = -I_F \left[\frac{\ell r_c + R_B}{\ell z_c + R_A + R_B} \right]$$

Armoured cable:

$$I_E = -I_F \left[\frac{\ell \left(\frac{r_c \times r_a}{r_c + r_a} \right) + R_B}{\ell \left(\left(\frac{r_c \times r_a}{r_c + r_a} \right) + r_c + j\omega(L_c + L_a) \right) + R_A + R_B} \right]$$

D.2.3 Line-cable circuit, remote source, fault at cable end

This arrangement is illustrated in Figure D.3.

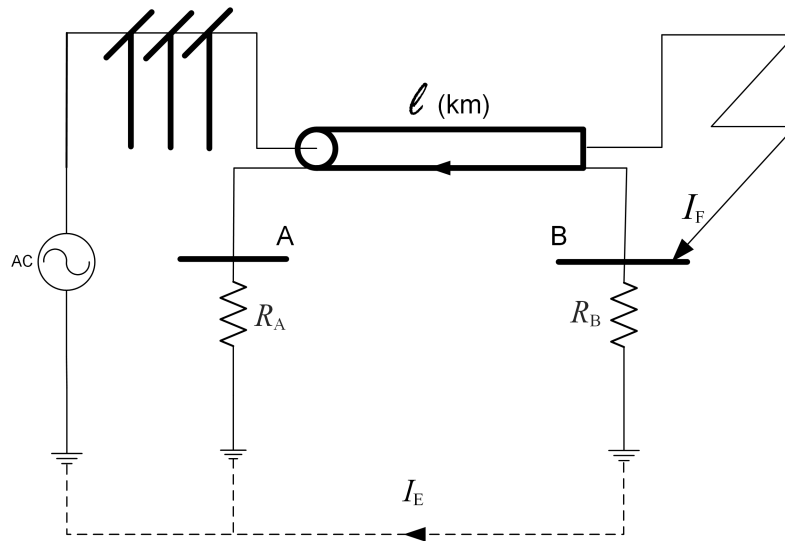

Figure D.3 — Line-cable circuit, remote source, fault at cable end

The following formulae may be used to calculate the ground return current (I_E) for the arrangement shown in Figure D.3 for 3-core armoured and unarmoured cables.

Unarmoured Cable:

$$I_{ES} = -I_F \left[\frac{\ell(z_c - z_{mp,c}) + R_A}{\ell z_c + R_A + R_B} \right] = -I_F \left[\frac{\ell r_c + R_A}{\ell z_c + R_A + R_B} \right]$$

Armoured cable:

$$I_{ES} = -I_F \left[\frac{\ell \left(\frac{r_c \times r_a}{r_c + r_a} \right) + R_A}{\ell \left(\left(\frac{r_c \times r_a}{r_c + r_a} \right) + r_c + j\omega(L_c + L_a) \right) + R_A + R_B} \right]$$

D.2.4 Line-cable-line circuit, remote source, remote fault

This arrangement is illustrated in Figure D.4.

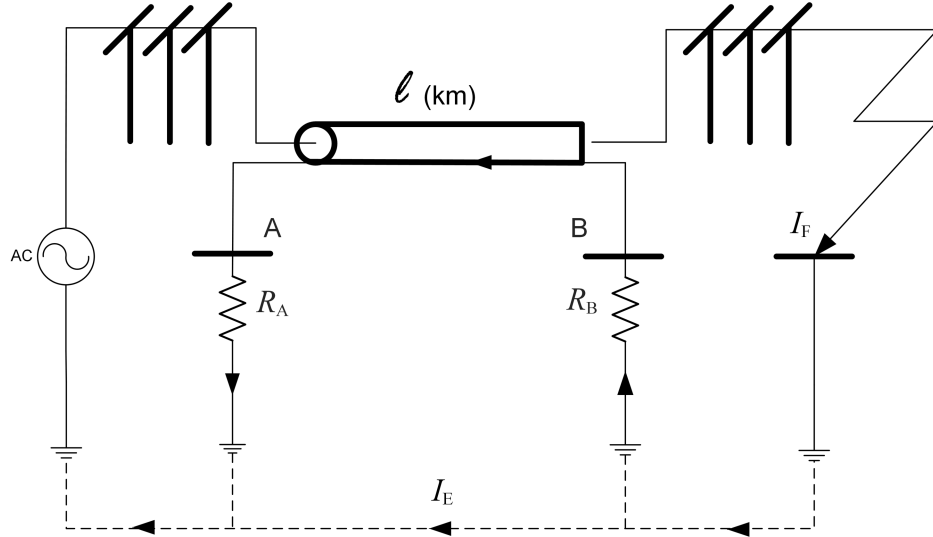

Figure D.4 — Line-cable-line circuit, remote source, remote fault

The following formulae may be used to calculate the ground return current (I_E) for the arrangement shown in Figure D.4 for 3-core armoured and unarmoured cables.

Unarmoured cable:

$$I_E = -I_F \left[\frac{\ell(z_c - z_{mp,c}) + R_A + R_B}{\ell z_c + R_A + R_B} \right] = -I_F \left[\frac{\ell r_c + R_A + R_B}{\ell z_c + R_A + R_B} \right]$$

Armoured cable:

$$I_E = -I_F \left[\frac{\ell \left(\frac{r_c \times r_a}{r_c + r_a} \right) + R_A + R_B}{\ell \left(\left(\frac{r_c \times r_a}{r_c + r_a} \right) + r_c + j\omega(L_c + L_a) \right) + R_A + R_B} \right]$$

D.3 Matrix method for single-core or triplex cables

D.3.1 Cable circuit, local source, fault at cable end

This arrangement is illustrated in Figure D.1. The cable sheaths are referenced 1, 2 and 3 with 1 associated to the faulted phase. The individual sheath currents I_1 , I_2 and I_3 are evaluated and I_E determined from the following matrix:

$$\begin{bmatrix} (R_A + \ell z_{c1} + R_B) & (R_A + \ell z_{m1,2} + R_B) & (R_A + \ell z_{m1,3} + R_B) \\ (R_A + \ell z_{m1,2} + R_B) & (R_A + \ell z_{c2} + R_B) & (R_A + \ell z_{m2,3} + R_B) \\ (R_A + \ell z_{m1,3} + R_B) & (R_A + \ell z_{m2,3} + R_B) & (R_A + \ell z_{c3} + R_B) \end{bmatrix} \begin{bmatrix} I_1 \\ I_2 \\ I_3 \end{bmatrix} = -I_F \begin{bmatrix} (R_A + \ell z_{mp,1} + R_B) \\ (R_A + \ell z_{mp,2} + R_B) \\ (R_A + \ell z_{mp,3} + R_B) \end{bmatrix}$$

$$I_E = -I_F - I_1 - I_2 - I_3$$

D.3.2 Cable-line circuit, local source, remote fault

This arrangement is illustrated in Figure D.2. The individual sheath currents I_1 , I_2 and I_3 are evaluated and I_E determined from the following matrix:

$$\begin{bmatrix} \text{[IMPEDANCE COEFFICIENTS]} \\ \text{AS IN D.3.1} \end{bmatrix} \begin{bmatrix} I_1 \\ I_2 \\ I_3 \end{bmatrix} = -I_F \begin{bmatrix} (\ell_{z_{mp,1}} + R_A) \\ (\ell_{z_{mp,2}} + R_A) \\ (\ell_{z_{mp,3}} + R_A) \end{bmatrix}$$

$$I_E = -I_F - I_1 - I_2 - I_3$$

D.3.3 Line-cable circuit, remote source, fault at cable end

This arrangement is illustrated in Figure D.3. The individual sheath currents I_1 , I_2 and I_3 are evaluated and I_E determined from the following matrix:

$$\begin{bmatrix} \text{[IMPEDANCE COEFFICIENTS]} \\ \text{AS IN D.3.1} \end{bmatrix} \begin{bmatrix} I_1 \\ I_2 \\ I_3 \end{bmatrix} = -I_F \begin{bmatrix} (\ell_{z_{mp,1}} + R_B) \\ (\ell_{z_{mp,2}} + R_B) \\ (\ell_{z_{mp,3}} + R_B) \end{bmatrix}$$

$$I_E = -I_F - I_1 - I_2 - I_3$$

D.3.4 Line-cable-line circuit, remote source, remote fault

This arrangement is illustrated in Figure D.4. The individual sheath currents I_1 , I_2 and I_3 are evaluated and I_{ES} determined from the following matrix:

$$\begin{bmatrix} \text{[IMPEDANCE COEFFICIENTS]} \\ \text{AS IN D.3.1} \end{bmatrix} \begin{bmatrix} I_1 \\ I_2 \\ I_3 \end{bmatrix} = -I_F \begin{bmatrix} (\ell_{z_{mp,1}}) \\ (\ell_{z_{mp,2}}) \\ (\ell_{z_{mp,3}}) \end{bmatrix}$$

$$I_E = -I_F - I_1 - I_2 - I_3$$

D.3.5 Formula parameters

The parameters used in the above formulae are as given in the list of symbols in Appendix A and as defined below.

The quantities z_c ; z_{c1} ; z_{c2} ; z_{c3} are the sheath to earth self impedances at 50 Hz and may be calculated as follows:

$$z_c = r_c + \left(49.4 + j62.8 \log_e \frac{93.2\sqrt{\rho}}{c_g} \right) \times 10^{-3} \quad (\Omega/\text{km})$$

where c_g is the GMR (Geometric Mean Radius) of the sheath (m).

The quantity r_c is the resistive component of the ground return path of the sheath to earth self impedance and is calculated to be:

$$r_c = 5\pi^2 10^{-3} (\Omega/\text{km})$$

The quantity L_c is the inductive component of the sheath to earth self impedance.

$$L_c = \left(0.2 \log_e \frac{93.2\sqrt{\rho}}{c_g} \right) \times 10^{-3} \text{ (H/km)}$$

The quantity L_a is the effective inductance of the armour wire.

$$L_a = \left(\frac{0.4\mu t}{d_i + t} \right) \times 10^{-3} \text{ (H/km)}$$

Where:

t is the thickness of the armour wire (m).

d_i is the internal diameter of the armour wire (m).

μ is the relative permeability of the armour material.

The quantities $z_{mp,c}$; $z_{mp,1}$; $z_{mp,2}$ and $z_{mp,3}$ are the faulted conductor-to-sheath mutual impedances and $z_{m1,2}$; $z_{m1,3}$ and $z_{m2,3}$ are the sheath-to-sheath mutual impedances at 50 Hz.

$$z_{mp,c} = \left(49.4 + j62.8 \log_e \frac{93.2\sqrt{\rho}}{d} \right) \times 10^{-3} \text{ (\Omega/km)}$$

where d is the centre to centre distance in metres between the conductors/sheaths.

In calculating $z_{mp,c}$; $z_{mp,1}$; $z_{mp,2}$ and $z_{mp,3}$ the value c_g should be substituted for d (where c_g is the GMR of the sheath (m)).

Table D.1 gives the values of Z_c and $z_{mp,c}$ for three-core cables in common use with an assumed value of ρ of 100 $\Omega \cdot \text{m}$.

Table D.1 — Self and mutual impedances for a sample of three-core cables

Operating voltage	Phase / core cross-sectional area	Cable type	Cable sheath self impedance (Z_c)	Mutual impedance between core and sheath / screen ($Z_{mp,c}$)	C-factors for arrangements shown in figures:		
					D.1	D.2 and D.3	D.4
11 kV	0.1 in ²	PILC SWA	1.221 ∠33.24°	0.672 ∠85.8°	57	55	56
11 kV	185 mm ²	PILC SWA	1.099 ∠41.6°	0.674 ∠85.8°	78	74	75
11 kV	300 mm ²	PILC SWA	0.873 ∠49.1°	0.622 ∠85.8°	97	93	93
11 kV	0.1 in ²	PILC	1.228 ∠33.7°	0.686 ∠85.88°	154	147	139
11 kV	185 mm ²	PILC	0.999 ∠41.66°	0.667 ∠85.77°	189	179	169
11 kV	300 mm ²	PILC	0.858 ∠49.53°	0.656 ∠85.69°	193	181	173
11 kV	185 mm ²	PICAS	0.677 ∠77.33°	0.662 ∠85.6°	30	26	26
11 kV	300 mm ²	PICAS	0.658 ∠79.6°	0.649 ∠85.7°	28	23	22
11 kV	185 mm ²	XLPE (50 mm ² CWS)	0.751 ∠59.46°	0.648 ∠85.64°	92	87	87
11 kV	300 mm ²	XLPE (50mm ² CWS)	0.744 ∠58.79°	0.639 ∠85.58°	130	122	121
33 kV	0.2in ²	PILC SWA	0.753 ∠58.62°	0.646 ∠85.63°	80	74	72
33 kV	185 mm ²	PILC SWA	0.769 ∠56.4°	0.651 ∠85.7°	--	--	--
33 kV	300 mm ²	PILC SWA	0.735 ∠60.3°	0.641 ∠85.6°	--	--	--
33 kV	0.2 in ²	PILC	0.753 ∠58.63°	0.646 ∠85.63°	138	129	125
33 kV	185 mm ²	PILC	0.771 ∠56.35°	0.659 ∠85.7°	173	159	152
33 kV	185 mm ²	PICAS	0.684 ∠74.0°	0.659 ∠85.7°	--	--	--
33 kV	300 mm ²	PICAS	0.856 ∠51.5°	0.672 ∠85.8°	--	--	--
132 kV	185 mm ²	PILC SWA	0.652 ∠76.0°	0.635 ∠85.6°	--	--	--

Operating voltage	Phase / core cross-sectional area	Cable type	Cable sheath self impedance (Z_c)	Mutual impedance between core and sheath / screen ($Z_{mp,c}$)	C-factors for arrangements shown in figures:		
					D.1	D.2 and D.3	D.4
132 kV	300 mm ²	PILC SWA	0.645 ∠76.7°	0.63 ∠85.5°	--	--	--
132 kV	185 mm ²	PICAS	0.636 ∠79.6°	0.628 ∠85.5°	--	--	--
132 kV	300 mm ²	PICAS	0.63 ∠80.2°	0.623 ∠85.5°	--	--	--
132 kV	185 mm ²	PILC	0.771 ∠56.35°	0.644 ∠85.62°	--	--	--
132 kV	300 mm ²	PILC	0.725 ∠60.98°	0.637 ∠85.57°	--	--	--

NOTE 1: In all cases the phase angle is negative.

NOTE 2: PILCSWA = paper insulated lead sheath covered steel wire armour; PILC = paper insulated lead sheath covered; PICAS= Paper insulated corrugated aluminium sheathed; TRIPLEX= 3 x single-core cables with XLPE or EPR insulation and 35 mm² stranded copper screen/cable (11kV and 33kV) or 135 mm² screen (132kV).

D.3.6 Self and mutual impedances for a sample of single-core distribution cables

Table D.2 gives values for self and mutual impedance for a sample of single-core underground cables commonly used in the UK.

Table D.2 — Self and mutual impedances for a sample of single-core (triplex) cables

Operating Voltage	Phase / Core Cross-sectional area	Cable type	Cable sheath self impedance, Z_c (Ω/km)	Mutual impedance between core and sheath / screen 1, $Z_{mp,1}$ (Ω/km)	Mutual impedance between core and sheath / screen 2/3, $Z_{mp,2} / Z_{mp,3}$ (Ω/km)	Mutual impedance between any two sheaths / screens, $Z_{m,x,y}$ (Ω/km)	C-factors for arrangements shown in figures:		
							D.1	D.2 and D.3	D.4
11kV	185mm ²	TRIPLEX	0.892 ∠51.8°	0.702 ∠85.98°	0.649 ∠85.65°	0.649 ∠85.65°	47	42	41
11kV	300mm ²	TRIPLEX	0.875 ∠52.0°	0.691 ∠85.91°	0.638 ∠85.58°	0.638 ∠85.58°	64	57	55
33kV	185mm ²	TRIPLEX	0.870 ∠51.48°	0.683 ∠85.86°	0.630 ∠85.52°	0.630 ∠85.52°	77	67	63
33kV	300mm ²	TRIPLEX	0.856 ∠51.5°	0.672 ∠85.8°	0.62 ∠85.44°	0.62 ∠85.44°	97	79	74
33kV	630mm ²	TRIPLEX	0.852 ∠50.5°	0.659 ∠85.7°	0.609 ∠85.3°	0.609 ∠85.3°	146	121	110

132kV	300mm ²	TRIPLEX	0.670 ∠74.78°	0.649 ∠85.65°	0.594 ∠85.25°	0.594 ∠85.25°	59	25	10
-------	--------------------	---------	------------------	------------------	------------------	------------------	----	----	----

NOTE 1: In all cases the phase angle is negative and the fault is assumed to be on phase / core 1.

NOTE 2: TRIPLEX = 3 x single-core cables with XLPE or EPR insulation and 35 mm² stranded copper screen/cable (11 kV and 33 kV, except 630 mm² which is aluminium) or 135 mm² screen (132kV).

NOTE 3: In the above table the three single-core cables are assumed to be in close trefoil (or triplex) formation and hence the three sheath-sheath mutual impedances are the same (i.e. $Z_{m,x,y} = Z_{m1,2} = Z_{m1,3} = Z_{m2,3}$). If the three-cores are arranged in a different configuration, e.g. flat or spaced trefoil, then self and mutual impedances shall be calculated and would be expected to be different.

D.4 Alternative formulae

The following empirical formulae can be used as an alternative to the formulae in D.2 for three-core cables, or as simplified formulae for single-core cables.

Where:

a is the cross sectional area (mm²)

C is the appropriate C -factor from Table D.1 or Table D.2

E is the system voltage (kV)

ℓ is the length (km)

$$R_{AB} = R_A + R_B$$

D.4.1 Cable circuit, local source, fault at cable end

This arrangement is illustrated in Figure D.1.

$$I_E = I_F \times \frac{\frac{C}{(a + 9E)}}{\sqrt{\left\{ \left(\frac{C}{a + 9E} + \frac{R_{AB}}{\ell} \right)^2 + 0.6 \left(\frac{\rho}{aE} \right)^{0.1} \right\}}}$$

D.4.2 Cable circuit, local source, remote fault

This arrangement is illustrated in Figure D.2.

$$I_E = I_F \times \frac{\frac{C}{(a + 9E)} + \frac{R_B}{\ell}}{\sqrt{\left\{ \left(\frac{C}{a + 9E} + \frac{R_{AB}}{\ell} \right)^2 + 0.6 \left(\frac{\rho}{aE} \right)^{0.1} \right\}}}$$

D.4.3 Line-cable circuit, remote source, fault at cable end

This arrangement is illustrated in Figure D.3.

$$I_E = I_F \times \frac{\frac{C}{(a + 9E)} + \frac{R_A}{\ell}}{\sqrt{\left\{ \left(\frac{C}{a + 9E} + \frac{R_{AB}}{\ell} \right)^2 + 0.6 \left(\frac{\rho}{aE} \right)^{0.1} \right\}}}$$

D.4.4 Line-cable-line circuit, remote source, remote fault

This arrangement is illustrated in Figure D.4.

$$I_E = I_F \times \frac{\frac{C}{(a + 9E)} + \frac{R_{AB}}{\ell}}{\sqrt{\left\{ \left(\frac{C}{a + 9E} + \frac{R_{AB}}{\ell} \right)^2 + 0.6 \left(\frac{\rho}{aE} \right)^{0.1} \right\}}}$$

Appendix E Ground return current for earth faults on steel tower supported circuits with an aerial earth wire

Values of ground return current I_E as a percentage of I_F and corresponding phase angle θ_E with respect to I_F for 132 kV, 275 kV and 400 kV line constructions

Table E.1 — Ground return current as % of earth fault current for tower lines

Type of line and conductor size (mm ²)	I_E as a percentage of I_F	Phase angle of I_E with respect to I_F (θ_E degrees lead)
132 kV (L4) (1 × 175)	70.8	171
132 kV (L7) (2 × 175)	63.6	177
275 kV (L3) (2 × 175)	66.9	178
275 kV (L2) (2 × 400)	68.6	178
400 kV (L8) (2 × 400)	70.0	179
400 kV (L6) (4 × 400)	69.2	179
400 kV (L9) (4 × 400)	64.0	179

Appendix F Typical values of earth resistance of long horizontal electrode

R_{EH} (Ω)

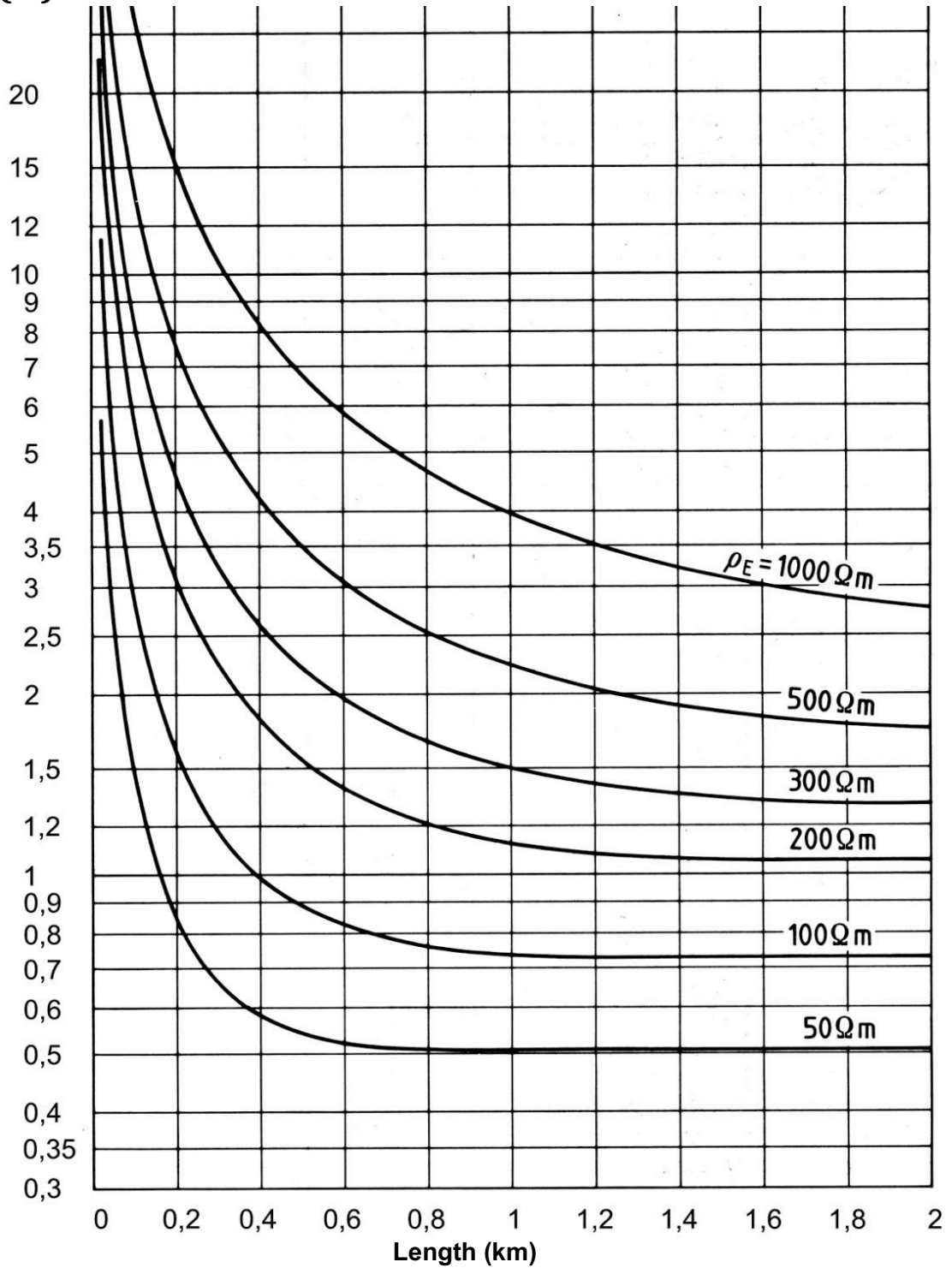

Figure F.1 — Typical values of earth resistance R_{EH} of long horizontal electrode
(taken from BS EN 50522)

Appendix G Chain impedance of standard 132kV earthed tower lines

Table G.1 gives chain impedances for a 132 kV L4 type construction with three towers/km and a “horse” earth wire (approx 70 mm² aluminium ACSR, to BS 215-2:1970).

Longitudinal impedance of earth wire is $0.443 + j 0.757 \Omega/\text{km}$ (calculated using Carson-Clem formula [5]).

The values assume more than 20 towers in series.

Table G.1 — Chain impedance for 132 kV tower lines

Footing resistance (Ω)	Chain impedance Z_{CH} (Ω) (complex notation)	Chain impedance Z_{CH} (Ω) (angular notation)
1	0.543+j0.414	0.683 \angle 37.35
2	0.737+j0.52	0.902 \angle 35.21
3	0.886+j0.603	1.072 \angle 34.24
4	1.012+j0.674	1.215 \angle 33.7
5	1.122+j0.736	1.342 \angle 33.26
6	1.222+j0.793	1.457 \angle 32.96
7	1.314+j0.845	1.562 \angle 32.73
8	1.4+j0.893	1.661 \angle 32.55
9	1.48+j0.939	1.753 \angle 32.39
10	1.556+j0.982	1.841 \angle 32.26
15	1.89+j1.172	2.224 \angle 31.82
20	2.17+j1.333	2.547 \angle 31.55
25	2.42+j1.474	2.832 \angle 31.37
40	3.039+j1.83	3.547 \angle 31.05

Appendix H The effect on ground return current for changes in geometry

H.1 Changes to the separation distance between three single-core cables laid flat or in trefoil

For the studies described below, three representative cables were selected for 11 kV and 132 kV voltage levels. Their details are given in Table H.1.

NOTE: The values provided in this section are for comparison purposes only, to illustrate the effect of cable laying only.

Table H.1 — Technical details of cables modelled

Operating voltage (kV)	Cable number	Phase conductor size (mm ²)	Insulation type	Insulation thickness (mm)	Core / Screen type + size (mm ²)	Reference cable code
132	1	630	XLPE	15	Lead	132_01_12
132	2	630	XLPE	21	Lead	132_01_13
132	3	630	XLPE	15	Copper wire 135	132_01_17
11	4	70	EPR		Copper wire 12	11_3_SZ
11	5	300	EPR		Copper wire 35	11_225_EPR
11	6	300	XLPE		Copper wire 70	11_21_S

The geometric arrangements considered are trefoil and flat. They are analysed on the basis that they are installed such that the cables are touching and assuming they are a symmetrical distance $3 \times D$ apart (where D is the outer cable diameter (mm)). See Table H.2 for details.

Table H.2 — Geometric placement of cables

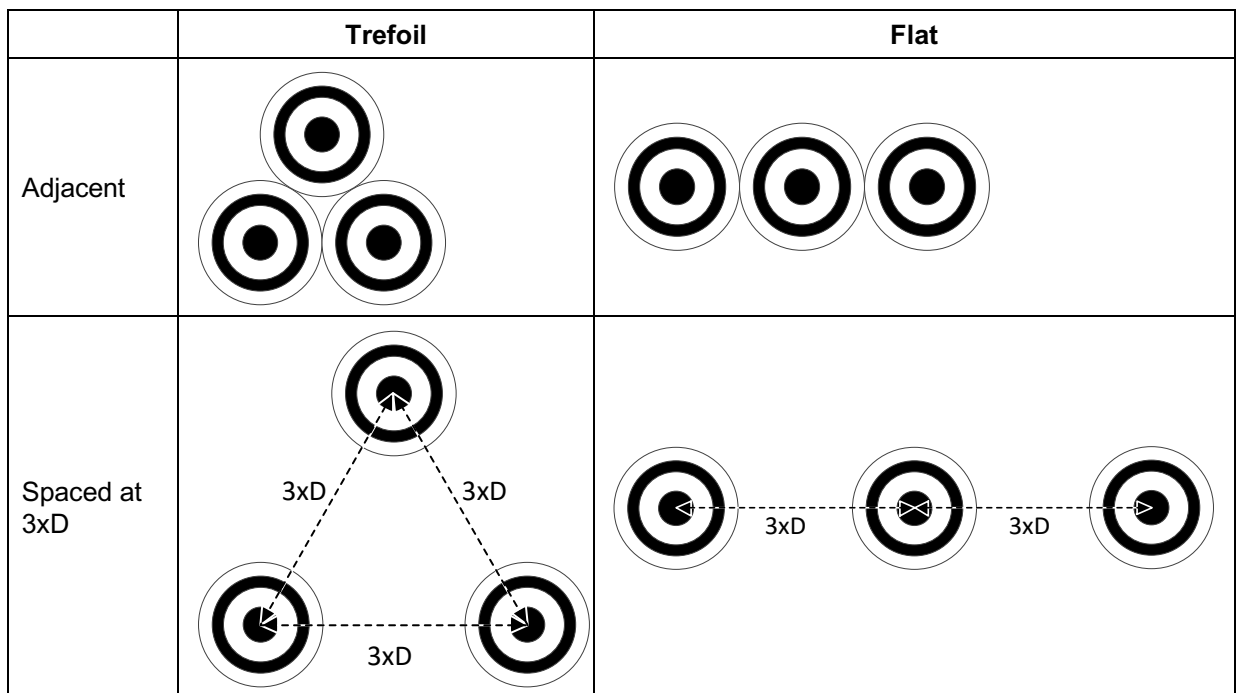

The 132kV cables were selected to show the difference that the sheath/screen configuration makes for the same size phase conductor. One standard cable contains a tubular conductor made of aluminium foil in addition to its stranded copper conductor. The cross-sectional view for this cable (trefoil format) is shown in Figure H.1.

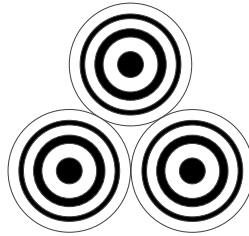

Figure H.1 — Cross-sectional view for cable 3

The circuit used to simulate the different cable arrangements and determine the effect on the earth return current is shown in Figure H.2. R_1 and R_2 are assumed nominal values of 0.5Ω .

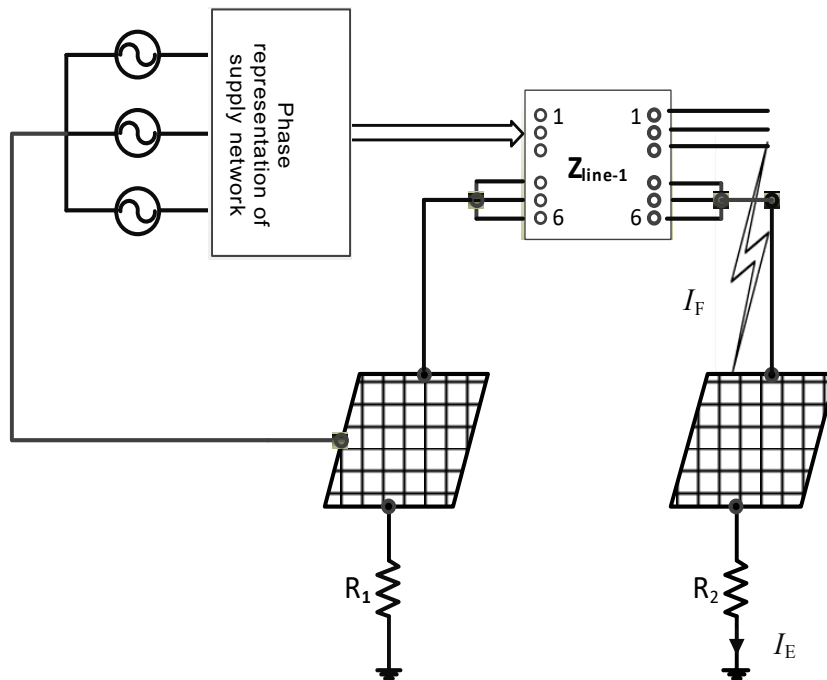
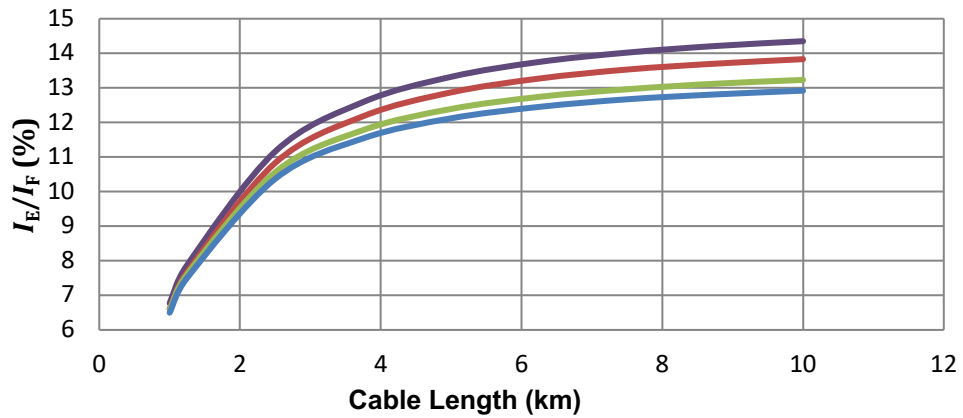

Figure H.2 — Circuit used for analysis purposes

Using the circuit described, studies were carried out for each of the cables of Table H.1 and the ground return current calculated for a set range of cable lengths. For each cable, four sets of studies were carried out, i.e. one for each physical arrangement of the individual cables shown in Table H.2.

The results are shown in Figure H.3 and Figure H.4, with the ground return current I_E shown as a percentage of the total earth fault current I_F .

Cable 1: 630 mm² with 15 mm XLPE, lead sheathed



Cable 2: 630 mm² with 21mm XLPE, lead sheathed

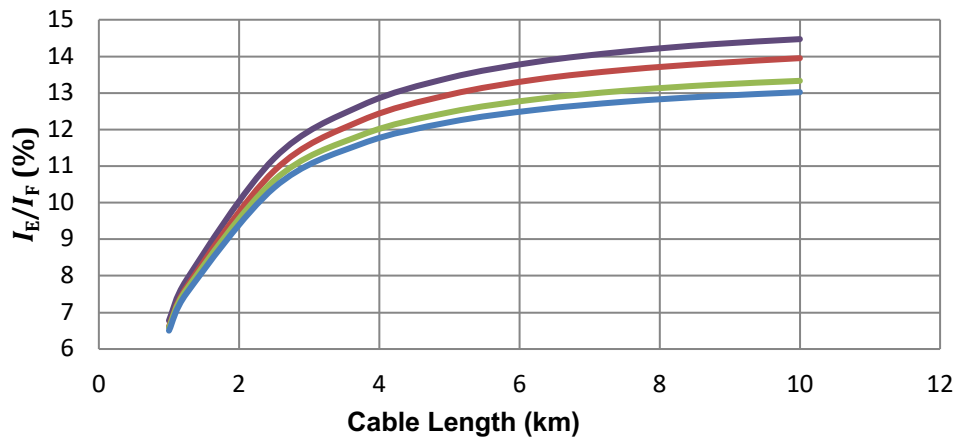

Cable 3: 630 mm² with 15 mm XLPE and composite screen/sheath (135 mm² Cu and 45 mm² Al)

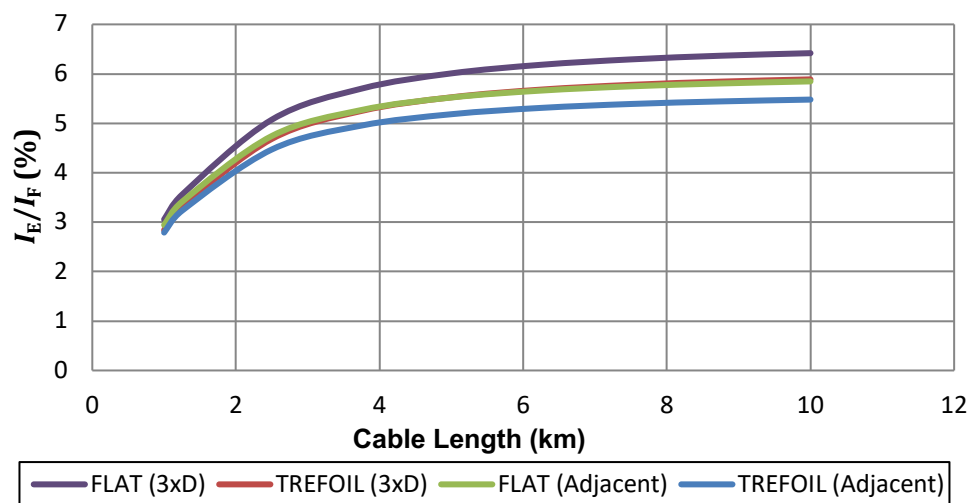
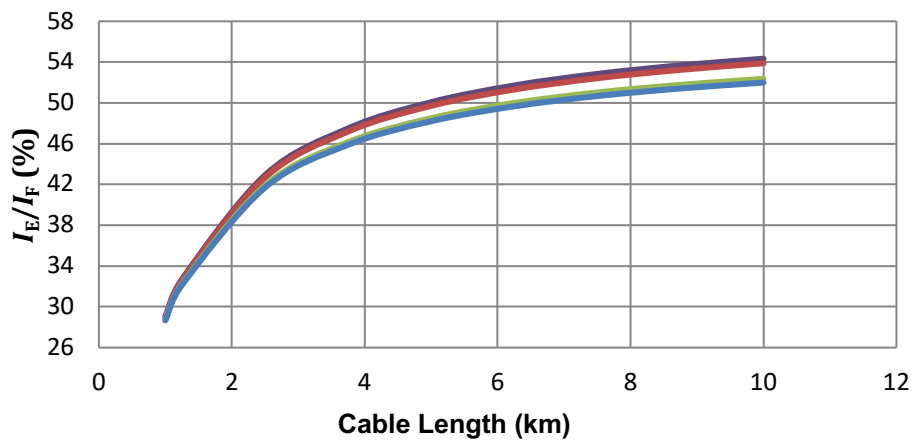
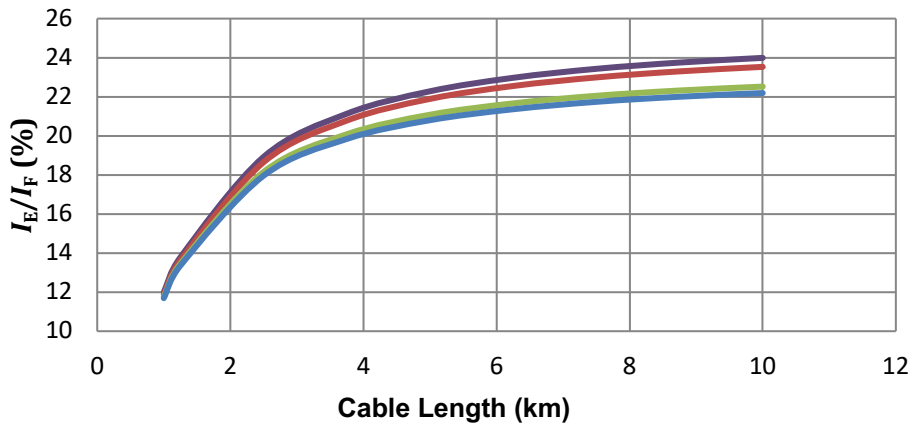

Figure H.3 — Ground return current (I_E) as a percentage of (I_F) against circuit length for different 132 kV cable installation arrangements

Cable 4: (70 mm² with 12 mm² Cu screen)



Cable 5: (300 mm² with 35 mm² Cu screen)



Cable 6: (300 mm² with 70 mm² Cu screen)

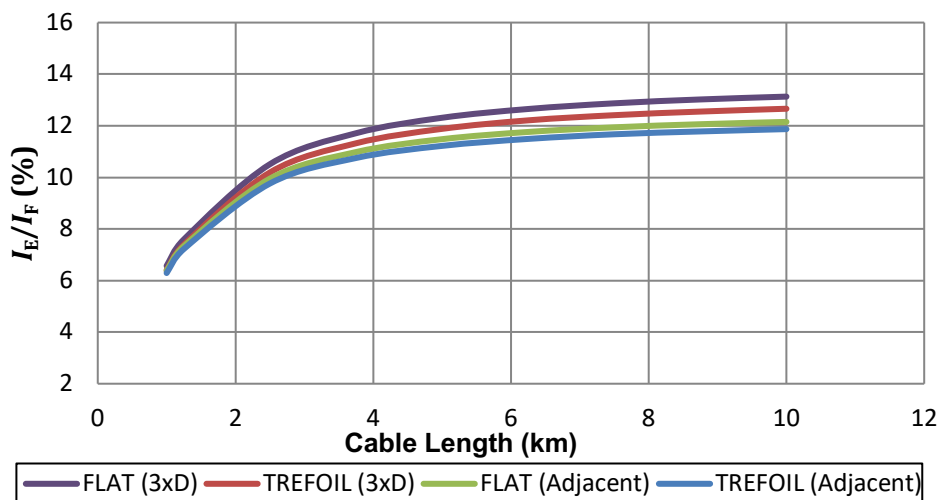

Figure H.4 — Ground return current (I_E) as a percentage of (I_F) against circuit length for different 11 kV cable installation arrangements

The results show that earth return current increases when the distance between adjacent cables is increased.

H.2 Conclusions

From Figure H.3 and Figure H.4, the following can be deduced.

Touching trefoil is the most effective arrangement in terms of minimising the ground return current. This is due to the more symmetrical arrangement and its impact on maximising mutual coupling effects. The ground return current increases in all cases in the following order:

- touching trefoil.
- touching flat.
- 3 x D trefoil.
- 3 x D flat.

The difference between trefoil and flat arrangements can be disregarded for most studies.

Other factors which influence the ground return current are:

- The circuit length.
- The electrical conductivity of the sheath/screen. This is illustrated when comparing the 132 kV composite screen (copper and aluminium) against a similar cable with a higher impedance lead screen (cables 3 and 1). A similar effect can be seen between cables 5 and 6. In the cables studied, the ground return current is approximately doubled for the cables with the higher impedance sheaths. The same effect is apparent with the 11 kV cables and cable 4 with its relatively small screen of 12 mm²/cable shows the importance of considering the screen size because the ground return current can reach almost 54% I_F for this cable.

Appendix I Transfer potential to distributed LV systems

I.1 Background

This issue relates to the transfer of voltage from HV systems to LV systems, when the LV system consists of multiple electrodes, as described in Section 5.4.

I.2 Examples

a) Equal LV electrode earth resistances

It is useful to consider a worked example where assumed typical values have been used and the transfer voltage has been calculated. Figure I.1 shows the circuit together with the calculated parameters.

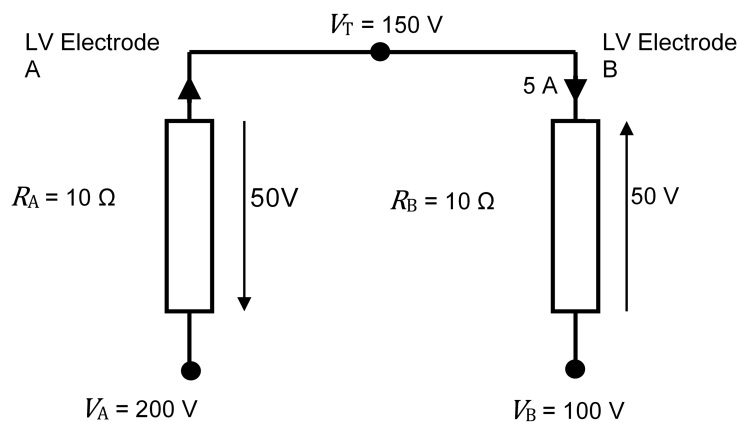

Figure I.1 — Example 1: Two electrodes of equal resistance

From Figure I.1, the surface potential experienced by electrodes A and B effectively act as voltage sources. Because electrodes A and B are connected together via an above ground conductor (assumed to have negligible resistance compared to the earth resistances) the potential difference of 100 V across the total series resistance of 20Ω causes a current of 5 A to circulate through the electrodes. This creates a voltage drop of 50 V across the earth resistance of A which is negative with respect to the local surface potential. This reduces the local electrode potential (by 50 V with respect to the local soil potential). Conversely at electrode B there is a 50 V drop across the earth resistance which increases the electrode potential by 50 V with respect to the local soil potential. The transfer potential on the combined LV electrode system is 150 V .

This explains the changes in surface potential contours around combined LV electrodes.

b) Unequal LV electrode earth resistances

Figure I.2 shows a similar example but where Electrode B has an earth resistance 5 times lower than Electrode A.

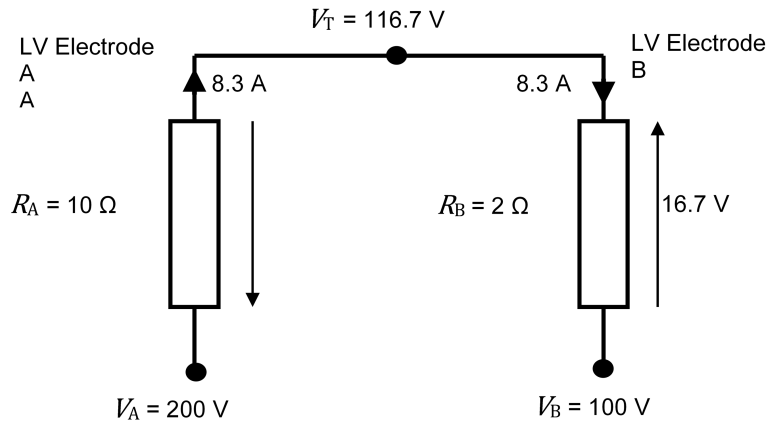

Figure I.2 — Example 2: Two electrodes of unequal resistance

It can be seen that the potential on the combined LV electrode is much lower than the average value of 150 V . Because electrode B has a much lower resistance it has a smaller potential drop across it and so the combined electrode potential is closer to the potential on electrode B.

c) More than two LV Electrodes

A similar calculation process can be applied to combinations of more than two LV electrodes. The formula below gives the combined electrode potential for three electrodes, A, B & C.

$$V_T = \frac{V_A(R_B R_C) + V_B(R_A R_C) + V_C(R_A R_B)}{(R_B R_C) + (R_A R_C) + (R_A R_B)}$$

The formula below allows a similar calculation to be made for four combined LV electrodes, A, B, C & D.

$$V_T = \frac{V_A(R_B R_C R_D) + V_B(R_A R_C R_D) + V_C(R_A R_B R_D) + V_D(R_A R_B R_C)}{(R_B R_C R_D) + (R_A R_C R_D) + (R_A R_B R_D) + (R_A R_B R_C)}$$

Further formulae for more than four combined LV electrodes can easily be produced by continuing this pattern and would be best implemented via a computer programme subroutine loop.

I.3 Discussion

This method has been found to provide a conservative estimate of transfer potential to LV earthing systems when the HV earth resistance is reasonably accurate, ideally determined by measurement. If calculated, conservative results are obtained if the formula for the earth resistance of a hemispherical electrode is used.

The above method may also be applied to a horizontal electrode which may be represented as a series of equally distributed vertical rods along its route. The coarsest representation is to model the horizontal electrode as two short vertical rods, the first at the point on the electrode nearest the HV electrode and the second at the furthest point. This method provides a conservative estimate of the transfer potential to the LV electrode. The greater number of rods used to model the horizontal electrode, the more accurate the calculated transfer potential becomes.

The method described above has been found to be reasonably accurate (and conservative) for soils with uniform resistivity and those where there is a lower resistivity deeper layer. Care should be taken when applying to soils where there is a high resistivity deeper layer, e.g. underlying rock, as transfer potentials may be underestimated and additional safety factors may need to be applied.

Where there is a distributed HV electrode system, e.g. where there are extended HV cables with bare sheaths in contact with the soil, the accuracy of this approach will depend on the location of the LV electrodes relative to the HV electrode. The approach may be valid if the LV electrodes are in the opposite direction to the HV electrode otherwise the transfer potential will need to be calculated by more detailed methods.

For detailed analysis of complex HV or LV electrode shapes and highly non-uniform soil resistivity structures, the use of computer simulation software will be required.

I.4 Application to real systems

The fact that the transfer potential is governed by the distance to the 'centre of gravity' of the LV electrode system from the HV electrode can help with the LV electrode design to minimise transfer potential. From this perspective, the best method is to install dominant parts of the LV electrode system as far as practicable from the HV electrode, i.e. towards the extremities of the LV system.

I.5 Worked example: Pole-mounted 11 kV/LV substation

A typical pole-mounted 11 kV substation arrangement is shown in Figure I.3. The HV and LV earthing systems are separated; in this example the transformer LV neutral/earth electrode is located 9 m away from the transformer HV earth electrode. A service cable provides an LV supply to a dwelling located 50 m away from the HV earth electrode and there is a LV PME earth electrode at the property.

The HV earth electrode is assumed to be a 3.6 m earth rod of 16 mm diameter and the soil resistivity is assumed to be 75 Ωm .

Using Formula R1, the HV electrode earth resistance is calculated to be 21.5 Ω . An earth fault current of 200 A is assumed to flow and is assumed to be disconnected in 1 s. The calculated EPR on the HV electrode is 4300 V.

The surface potential 9 m away from the HV electrode can be calculated using Formula P6.2 as 259V and would be experienced by LV earth electrode 1. In the absence of any additional LV earth electrodes, this voltage would be propagated through the LV neutral/earth conductor and may be experienced as a touch voltage by the dwelling occupants. This potential exceeds the permissible touch voltage for 1 s of 233 V and so would not be acceptable.

Figure I.3 shows a second LV electrode (LV earth electrode 2) located at the dwelling that is 50 m away from the HV electrode. Use of Formula P6.2 gives a calculated surface potential of 48 V that would be experienced by LV earth electrode 2.

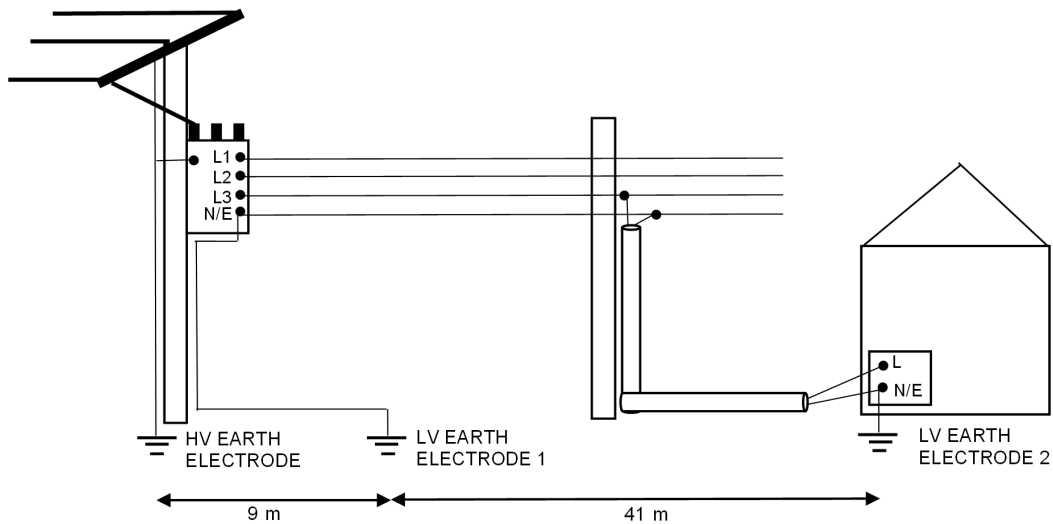

Figure I.3 — Example of pole-mounted 11 kV substation arrangement and LV supply to a dwelling

Because LV earth electrodes 1 and 2 are connected via the LV neutral/earth conductor, and assuming they each have a similar earth resistance, the transfer potential on the LV earthing system (both electrodes and the interconnecting conductor) will be the average of the surface potential calculated at each LV electrode location, i.e. 154 V which is below the permissible touch voltage.

If the resistance of LV earth electrode 2 was half that of LV earth electrode 1 the average potential will be weighted more towards the potential at LV earth electrode 2. From the formula in section 5.4.2, the combined potential on the LV earthing system would be $(259 \times 1 + 48 \times 2) / 3 = 118$ V.

This rather straightforward example illustrates how the electrode arrangement can be designed to significantly reduce the transfer potential.

Bibliography

Standards publications

For dated references, only the edition cited applies. For undated references, the latest edition of the referenced document (including any amendments) applies.

IEC 60287-3-1:2017, *Electric cables – Calculation of the current rating – Part 3-1: Operating conditions – Site reference conditions*

IEC 60949:1988, *Calculation of thermally permissible short-circuit currents, taking into account non-adiabatic heating effects*

PD IEC/TS 60479-1:2005+A1:2016, *Effects of current on human beings and livestock. General aspects*

BS 215-2: 1970, *Specification for aluminium conductors and aluminium conductors, steel-reinforced for overhead power transmission. Aluminium conductors, steel-reinforced*

BS 7430:2011+A1:2015, *Code of practice for protective earthing of electrical installations*

ENA EREC S36-1, *Identification and Recording of Hot Sites - Joint Electricity / British Telecom Procedure*

IEEE 80, *Guide for Safety in AC Substation Grounding*

Other publications

[1] [Davies, M., Charlton, T., Baudin, D.] New design methods to achieve greater safety in low voltage systems during a high voltage earth fault, CIRED Conference, Frankfurt, June 2011

[2] [HSE] Reducing Risk Protecting People (R2P2)

[3] [Sunde, E.D] Earth conduction effects in transmission systems, Dover Publications, 1967, pp75-79

[4] [Schwarz, S. J.] Analytical expression for resistance of grounding systems, AIEE Transactions on Power Apparatus and Systems, vol. 73, no. 13, part III-B, pp. 1011–1016, Aug. 1954.

[5] [Clem, J. E.], "Reactance of transmission lines with ground return," AIEE Transactions on Power Apparatus and Systems, vol. PAS-50, pp. 901–918, Sept. 1931.

Further reading

SI 2002 no.2665, The Electricity Safety, Quality and Continuity Regulations 2002 (as amended)

SI 2012 no. 381, The Electricity Safety, Quality and Continuity (Northern Ireland) Regulations 2012 (as amended)

ENA ETR 128, *Risk assessment for BT operators working in a ROEP zone*

ENA ETR 129, *ROEP risk assessment for third parties using equipment connected to BT lines*